

EUREPGAP

General Regulations Fruit and Vegetables

Version 2.1-Jan04

Valid from: 12th September 2003

CONTENTS**Page N°**

| | |
|---|----|
| 1. EUREPGAP TERMS OF REFERENCE | 3 |
| 2. SCOPE OF THIS DOCUMENT | 3 |
| 3. OBJECTIVES | 4 |
| 4. FARMER CERTIFICATION PROCESS FLOWCHART | 5 |
| 5. INTRODUCTION | 6 |
| 6. RULES..... | 9 |
| 7. COMPLIANCE LEVELS FOR EUREPGAP CERTIFICATION..... | 11 |
| 8. OPTIONS AND VERIFICATION FOR EUREPGAP CERTIFICATION | 11 |
| 9. RIGHTS AND OBLIGATIONS OF EUREPGAP APPLICANTS | 13 |
| 10. EUREPGAP CERTIFICATE GRANTING PROCESS | 14 |
| 11. SANCTIONS..... | 20 |
| 12. NON-COMPLIANCES | 21 |
| 13. SANCTIONS AND NON-COMPLIANCES APPLICATION..... | 23 |
| 14. NOTIFICATION OF SANCTIONS, NON-COMPLIANCES AND APPEALS | 24 |
| 15. HARMONISATION PROCEDURE..... | 25 |
| 16. APPENDIX 1: REQUIREMENTS FOR EUREPGAP FRUIT AND VEGETABLES AUDITOR..... | 26 |
| 17. APPENDIX 2: REQUIREMENTS FOR EUREPGAP FRUIT AND VEGETABLES INSPECTOR | 28 |
| 18. APPENDIX 3: REQUIREMENTS FOR INTERNAL FARMER GROUP INSPECTOR..... | 30 |
| 19. APPENDIX 4: CERTIFICATE CONTENTS..... | 31 |

1. EUREPGAP TERMS OF REFERENCE

“The Global Partnership for Safe and Sustainable Agriculture”

To respond to Consumer Concerns on Food Safety, Animal Welfare, Environmental Protection and Worker Health, Safety and Welfare by:

- 1.1 Encouraging adoption of commercially viable Farm Assurance Schemes, which promote the minimisation of agrochemical inputs, within Europe and Worldwide
- 1.2 Developing a Good Agricultural Practice (GAP) Framework for benchmarking existing Assurance Schemes and Standards including traceability.
- 1.3 Providing guidance for continuous improvement and the development and understanding of best practice.
- 1.4 Establishing a single, recognised framework for independent verification.
- 1.5 Communicating and consulting openly with consumers and key partners, including producers, exporters and importers.

2. SCOPE OF THIS DOCUMENT

This document explains the structure of certification to EUREPGAP Standard for *Fruit and Vegetables*, and the procedures that should be followed in order to obtain and maintain Certification. It details the duties and rights of the EUREPGAP Secretariat, Certifiers and Farmers applying for Certification.

This document shares many parts with the General Regulations of other Standards managed by EUREPGAP. These parts are written in standard form, whereas those bodies of text (not titles) that are applicable only to the Fruit and Vegetables scope are in *italics*.

The scope of *Fruit and Vegetables* covers all those *fresh, unprocessed agricultural products of plant origin grown for human consumption*.

This is a EUREPGAP normative document.

3. OBJECTIVES

3.1 EUREPGAP scheme principles are based on the EUREPGAP Terms of Reference and specifically on the following concepts:

3.1.1 Food Safety:

The standard is based on Food Safety criteria, derived from the application of generic HACCP principles.

3.1.2 Environment Protection

The standard consists of Environmental Protection Good Agricultural Practices, which are designed to minimise negative impacts of Agricultural Production on the Environment.

3.1.3 Occupational Health, Safety and Welfare:

The standard establishes a global level of occupational health and safety criteria on farms, as well as awareness and responsibility regarding socially related issues; however it is not a substitute for in-depth audits on Corporate Social Responsibility.

3.1.4 Animal Welfare (where applicable):

The standard establishes a global level of animal welfare criteria on farms.

3.2 EUREPGAP is a global Scheme and Reference for Good Agricultural Practice, which is managed by the EUREPGAP Secretariat.

3.3 FoodPLUS is a non-profit, industry owned and governed organisation that legally represents the EUREPGAP Secretariat, registered at the following address: Spichernstrasse 55, D-50672 Köln (Cologne) – Germany.

3.4 The objective of this document is to explain and regulate the operation of the EUREPGAP Scheme and the interaction between the Certification Bodies (from now on CBs), the Registered Farmer or Farmer Group, the schemes seeking equivalence acceptance and the EUREPGAP Secretariat.

3.5 EUREPGAP provides the standards and framework for Independent, recognised Third Party Certification of Farm Production Processes based on (EN45011/ISO Guide 65). (Certification of the production process – producing, growing or “cropping” – of these products ensures that only those that reach a certain level of compliance with established Good Agricultural Practices set out in the EUREPGAP normative documents are certified).

3.6 The Scheme covers the whole agricultural production process of the certified Product, from *before the plant is in the ground (seed and nursery control points) to non-processed end product (Produce Handling control points)*.

3.7 Participation is voluntary and based on objective criteria. EUREPGAP is not discriminatory to Certification Bodies and/or Farmers.

4. FARMER CERTIFICATION PROCESS FLOWCHART

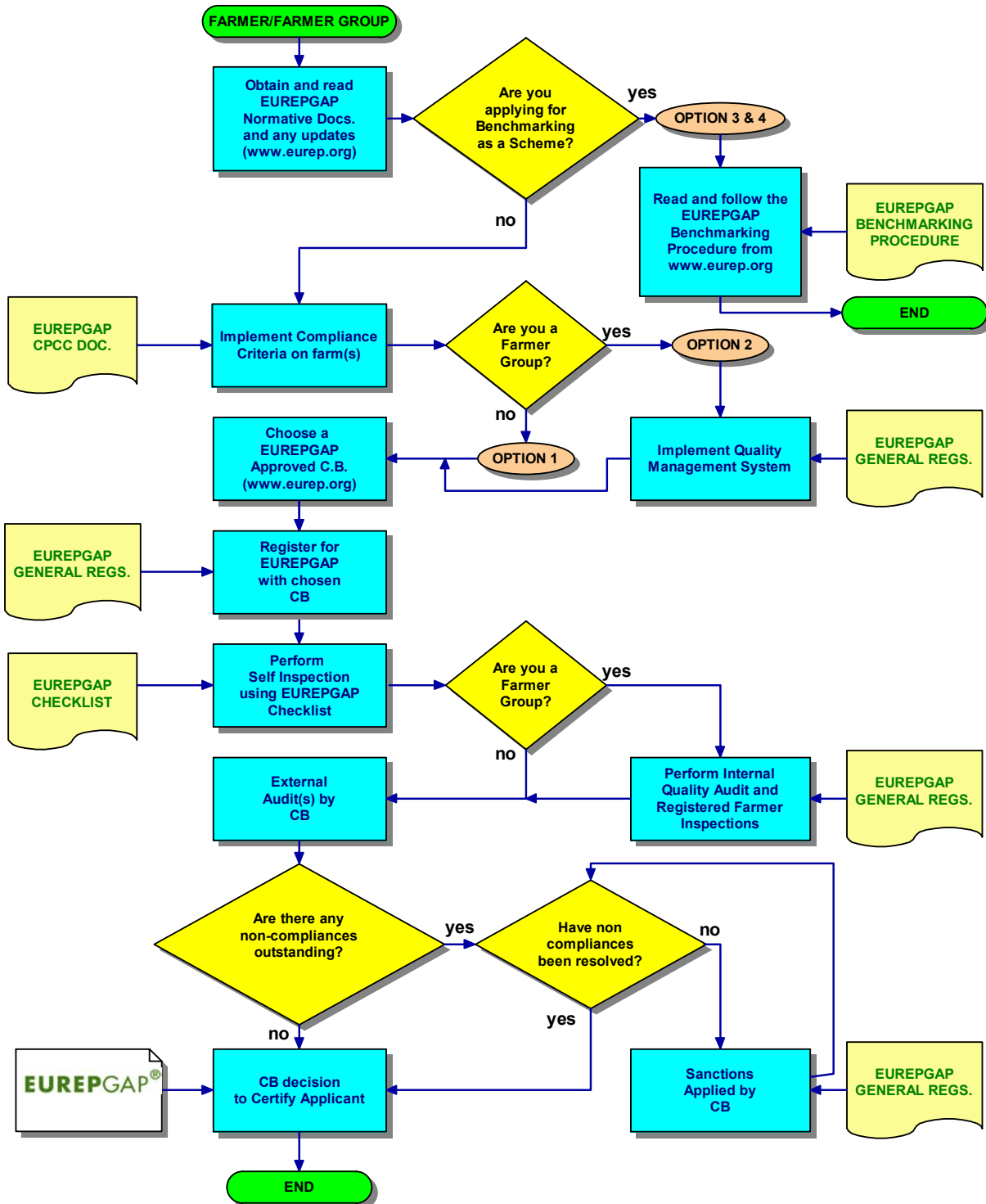

5. INTRODUCTION

5.1 Structure

This document is composed of:

5.1.1 Main Body

It describes the basic steps and consideration involved for the Applicant Farmer to obtain and maintain EUREPGAP Certification and Approval, and the role and relationship of Farmers, EUREPGAP and CBs.

5.1.2 Appendices:

A set of appendices go into further detail and constitute a reference in specific areas and complement the main body, which together form the General Regulations as such. These Appendices are always normative.

5.1.3 Annexes:

A set of Annexes that provide additional information, giving specific guidance and references. Annexes are Documents that exist for clarification, they maintain their own identity and may be modified and referred to independently.

5.2 Reference Documents (excluding those annexes mentioned below)

- (i) EUREPGAP Sub-Licence Agreement Contract.
- (ii) *EUREPGAP Control Points and Compliance Criteria for Fruit and Vegetables*
- (iii) *EUREPGAP Checklist for Fruit and Vegetables*
- (iv) EUREPGAP Benchmarking Cross Reference Document
- (v) EUREPGAP Benchmarking Procedure_OV1.0-May03
- (vi) ISO 9000:2000
- (vii) EN 45011 / ISO Guide 65
- (viii) EN 45004 / ISO Guide 17020

5.3 Annexes:

| N° | Name | Code Ref. |
|-----------|--|------------------------|
| 1 | Trademark, Logo and Registration Number Use | <i>FP 2.1 GR A1-x*</i> |
| 2 | Farmer Group Quality Management Systems | <i>FP 2.1 GR A2-x</i> |
| 3 | Guidelines for CB evaluation of Quality Management Systems | <i>FP 2.1 GR A3-x</i> |
| 4 | Subcontractors | <i>FP 2.1 GR A4-x</i> |
| 5 | Approved EUREPGAP CB commitments | <i>FP 2.1 GR A5-x</i> |
| 6 | Transfer between CBs | <i>FP 2.1 GR A6-x</i> |
| 7 | EUREPGAP Product Crop list | <i>FP 2.1 GR A7-x</i> |
| 8 | Current Language Editions and Status | <i>FP 2.1 GR A8-x</i> |
| 9 | EUREPGAP Non-Compliances Record Sheet | <i>FP 2.1 GR A9-x</i> |
| 10 | EUREPGAP Definitions | <i>FP 2.1 GR A10-x</i> |
| 11 | <i>Fruit and Vegetables</i> Edition Updates and Valid Version Register | <i>FP 2.1 GR A11-x</i> |

* x is the latest annex edition update number, refer to Annex 11 for up to date information.

5.4 Other languages

The English language edition of this and other EUREPGAP Documents are the original editions. EUREPGAP Documents will be translated into other languages. Once published, these official EUREPGAP documents will be the only ones that may be used for EUREPGAP Certification in that language. Translated documents will be identified as having normative status once a EUREPGAP Technical Working Group proposes it and only after a thorough translation review by the Group and approval by the TSC (this forms part of the EUREPGAP Technical Working Groups Terms of Reference). Until they reach normative status, the sentence “please refer to the English version in case of doubt” will be written on each sheet of the translated documents, in the respective language.

Accreditation may be sought and obtained by Certifiers in other languages only against documents with normative status recognised in this way. For a list of the current language editions of EUREPGAP documents and their status refer to Annex 8.

5.5 Official Communications Updates

From time to time EUREPGAP will issue CBs with edition updates to this General Regulations document or its annexes, which will be added into Annex 11 for reference. These updates will be sent to all EUREPGAP Approved CBs as official communications, and will form part of the normative document and must therefore be followed. Each update will state the dates that the updates come into force of the update and the date that the previous edition becomes obsolete.

5.6 Abbreviations used

- (i) CB: Certification Body
- (ii) CPCC: Control Points and Compliance Criteria
- (iii) CP: Control Point
- (iv) GPS: Global Positioning System
- (v) N^o: Number.
- (vi) IAF: International Accreditation Forum
- (vii) MLA: Multilateral Agreement
- (viii) TSC: Technical and Standards Committee EUREPGAP

5.7 Definitions

Refer to annex 10

5.8 Introduction of new Version and Obsolete Documentation:

This normative document comes into force on the 12th of September 2003 and will be introduced as described below, replacing “EUREPGAP General Regulations version Sept 2001, Rev. 01”:

- (i) *Publication date:* 12th Sep 2003
- (ii) *Can be certified from:* 12th Sep 2003
- (iii) *Last certification date for Version Sept 2001 Rev 01:* 31st Dec 2004
- (iv) *Latest expiry Ver. Sept 2001 Rev 01 Certificates:* 31st Dec 2005
- (v) *Equivalent schemes must update Standard by:* 31st Dec 2004
- (vi) *Latest expiry Ver. Sept 2001 Rev 01 Equivalent Scheme Certificates:* 31st Dec 2005
- (vii) *Farmers may apply for registration of version 2.1 with CBs from:* 12th Sep 2003
- (viii) *Farmers may not apply for registration under version 2001 after:* 31st Dec 2004

5.8.1 Flowchart showing dates for Introduction of new Version and phasing out of Obsolete Version of Standard:

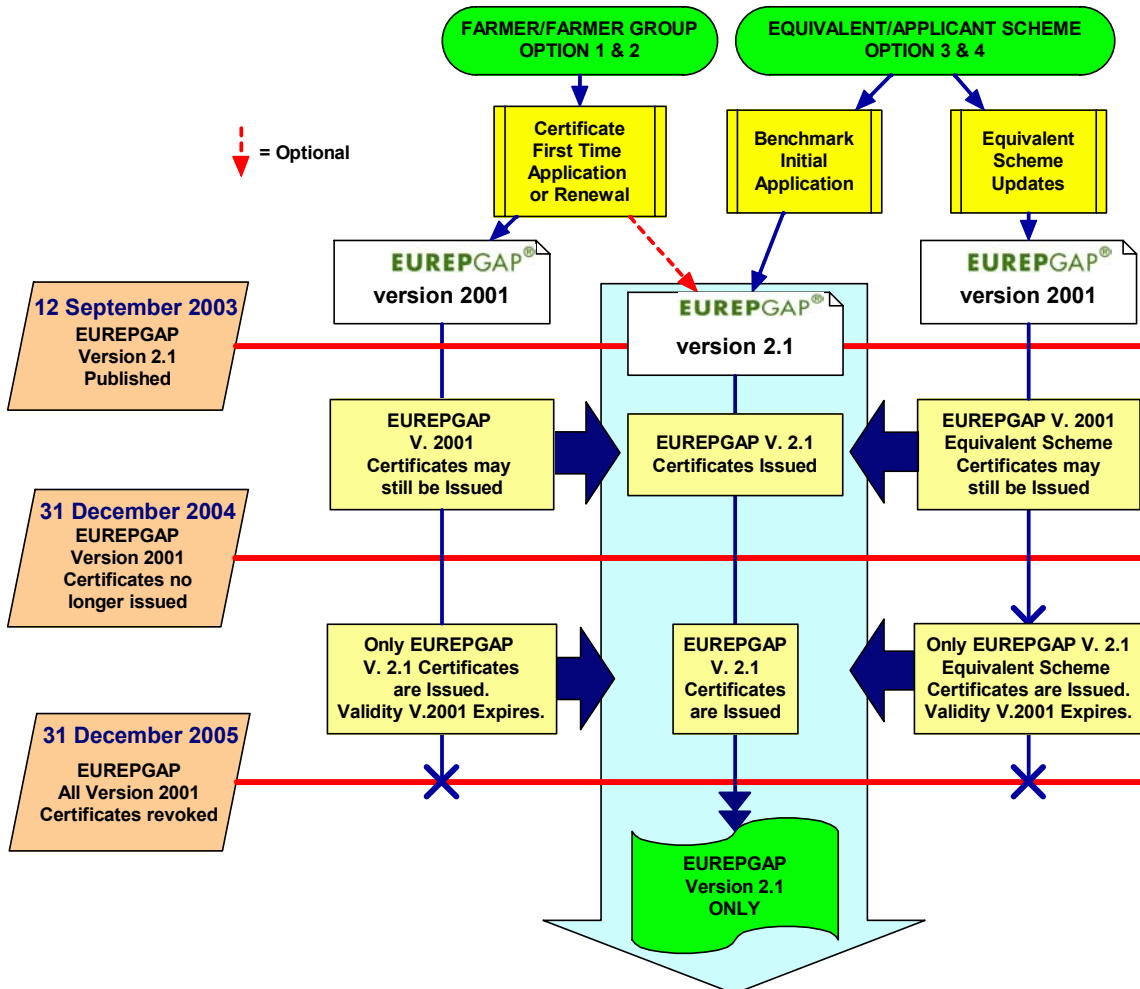

5.9 Version Handling:

5.9.1 Document Names:

Version means the name of the EUREPGAP normative document. The Versions of normative documents within EUREPGAP are consecutive, thus Version "2.1"Jan"04" can be sectioned out and understood reading the values as follows: "edition n°."edition update n°"month of update"- "year of Introduction".

The "." between the edition n° and the edition update n° may be expressed as a "-" in certain cases such as file names in order to enable web-based application. For the current General Regulations Version, the edition number starts at 2, the edition update number starts at 1, and the month of update starts at Jan04, there having been a pre-release Version called 2.0-Jan04 which has been subsequently updated (see Annex 11 for updated information). The first edition update date is set at Jan04 to help set the old and the new Versions more clearly apart in time.

A code appears on the right at the top of each document identifying it within the EUREPGAP context, thus "FP" "2.1" "GR" means "Fresh Produce" "Edition 2.1" "General Regulations". – this code may be used especially to identify the context of the Annexes.

5.9.2 Annexes

Annexes may be modified independently of the rest of the normative document, identifying the latest update by changing the Annex Edition number in a similar way as the Normative Document Version, thus Annex names are for example "A"10"-0", this means that this is "Annex" "10" – "Edition 0".

5.9.3 Edition Updates:

Each EUREPGAP normative document edition may be updated at different intervals as the need to modify their content may arise, therefore for example General Regulations Version 2.1-Jan04 that applies to the most current CPCC could be named with a different edition update n°, such as Version 2.0-Jan04. Annex edition n°s are consecutive and independent from the General Regulation Edition update n°s, for example General Regulations Version 2.1-Jan04 may contain Annex A10-2. If the GR Version were to change to 2.2-Mar 04 for example, (and the content of Annex A 10-2 is not modified), then the annex would remain as Annex A10-2. If on the other hand the content of the Annex A 10-2 were modified, then it would be re-named A10-3, the next consecutive number after 2.. Complete new Versions are edited at regular, announced dates (once every so many years)..

6. RULES

- 6.1 These General Regulations establish the rules applicable to CBs approved by EUREPGAP Secretariat to the scope of *EUREPGAP Fruit and Vegetables*, for granting, maintaining and removing EUREPGAP *Fruit and Vegetables* certification. Certificate owner can be any of the following:
- 6.1.1 **Individual Farmer applying for EUREPGAP Certification**
 - 6.1.2 **Farmer Group applying for EUREPGAP Certification**
 - 6.1.3 **Farmer and/or Farmer Group working under a Scheme that has successfully benchmarked to EUREPGAP**
- 6.2 EUREPGAP issues licences to approved CBs, who are thus empowered to issue certificates of compliance to the EUREPGAP standard.
- 6.3 The certificate is the document that a Farmer holds to show he has been certified, and the licence is a contractual relationship that EUREPGAP and the Farmer or Farmer Group enter into by means of a Sub-licence Agreement signed between the Farmer and the EUREPGAP Approved CB.

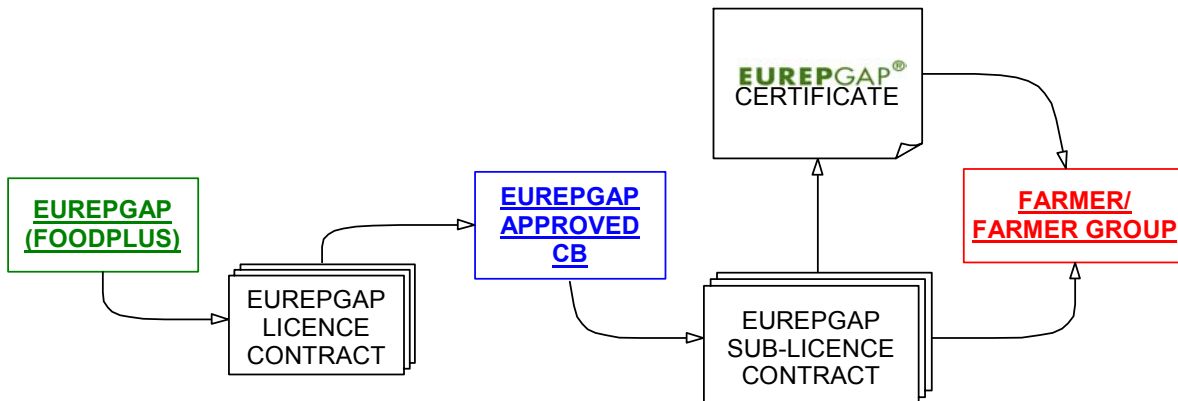

- 6.4 The Sub-licence agreement is published by EUREPGAP in different languages – only the official EUREPGAP translation may be used for the languages in which it is available.
- 6.5 EUREPGAP is a registered trade mark. The use of this registered trademark is regulated by the EUREPGAP Secretariat, specified in the Trademark and Logo Use Guidelines, (refer to Annex 1)
- 6.6 **The normative documents that conform the EUREPGAP Scheme** are the following:
- 6.6.1 EUREPGAP General Regulations:**
Provides instructions as to how the Certificate can be applied for, obtained and maintained and the rights and responsibilities involved, with annexes that go into further detail.
- 6.6.2 EUREPGAP Control Points and Compliance Criteria:**
Contains all the Control Points and Compliance Criteria that must be followed by the Applicant Farmer/Farmer Group and which are audited to verify compliance. This document is divided into 14 sections and it lists *Major Musts in red (47 Control Points)*, *Minor Musts in yellow (98 Control Points)* and *Recommended (65 Control Points) in Green, with a total of 210 Control Points*.
- 6.6.3 EUREPGAP Checklist:**
Contains the Control Points and is a tool for inspecting and evaluating compliance.
- 6.7 Excerpts of these normative documents may be published from time to time by EUREPGAP, but these do not constitute normative documents in their own right.
- 6.8 **In addition to these Normative Documents**, Guidelines for dealing with general interpretation and application of Control Points within the CPCC *Fruit and Vegetables* **and** Guidelines dealing with specific geographic and cultural differences may be approved and issued by the *TSC Fruit and Vegetables*, with support from the recognised EUREPGAP Regional or National Technical Working Groups. These Guidelines will also define their scopes of application (general application scope or specifically defined Geographic areas and/or product groups respectively. Transition and implementation rules will be set within the guidelines, and application is mandatory for all CBs and Farmers / Farmer Groups operating within the defined application scopes of the Guidelines

7. COMPLIANCE LEVELS FOR EUREPGAP CERTIFICATION

7.1 Compliance with EUREPGAP *Fruit and Vegetables* consists of *three types* of control points, that the applicant is required to undertake in order to obtain EUREPGAP recognition; **MAJOR MUSTS**, **MINOR MUSTS** and **RECOMMENDATIONS**, and must be fulfilled as follows: (See also chapters 11 & 12 of this document, Sanctions and Non-compliances)

7.1.1 MAJOR MUSTS:

100% compliance of all Applicable Major Must Control Points is compulsory.

7.1.2 MINOR MUSTS:

95% compliance of all applicable Minor Must Control Points is compulsory. For the sake of calculation, the following formula will apply.

$$\left\{ \begin{array}{l} \text{(Total number of} \\ \text{Minor Must} \\ \text{Control Points)} \end{array} \right. - \begin{array}{l} \text{(Not Applicable} \\ \text{Minor Musts Control} \\ \text{Points} \\ \text{Scored on the farm)} \end{array} \left. \right\} \times 5\% = \begin{array}{l} \text{(Total Minor Must} \\ \text{Control Point Non} \\ \text{compliance} \\ \text{allowable)} \end{array}$$

7.1.3 RECOMMENDATIONS:

No minimum percentage of compliance is set.

7.2 All Control Points in the CPCC must be audited, *including the RECOMMENDATIONS*.

7.3 Control Points that are indicated by "No N/A" in the Compliance Criteria field, unless specifically indicated in the respective Compliance Criteria text, must be audited and may not be justified as being "not applicable". Exceptions can only be granted by the EUREPGAP Technical and Standards Committee for *Fruit and Vegetables* and will be published by EUREPGAP as an annex to the CPCC.

8. OPTIONS AND VERIFICATION FOR EUREPGAP CERTIFICATION

Farmers can achieve EUREPGAP certification under any one of the four Options described below.

8.1 OPTION 1: Individual Certification

Individual Farmer applies for EUREPGAP certificate.

8.1.1 Farmer internal self-inspection:

- (i) A completed internal self-inspection based on the EUREPGAP Checklist must be available on site for review by the external inspector during the external inspection process.
- (ii) The internal self-inspection must be carried out at least once a year. This internal self-inspection will be carried out under the responsibility of the Individual Farmer.

8.1.2 External verification by EUREPGAP approved CB:

- (i) A minimum of one announced external inspection carried out by the EUREPGAP approved CB per annum of the registered farm *and all declared produce handling sites*.

- (ii) The granting CB (or its subcontracted agent, refer to Annex 5) will carry out an additional minimum of 10% unannounced inspections per annum among all certified Farmers it has registered under Option 1. External CB Farm inspections can be carried out either by a EUREPGAP Inspector or a EUREPGAP Auditor (see Appendix 1 and 2 respectively).
- (iii) The external inspection reports will be prepared in accordance with the requirements of EN 45011/ ISO Guide 65.

8.2 OPTION 2: Group Certification

Farmer Group applies for EUREPGAP Group Certificate.

8.2.1 Internal Management and Control System:

- (i) A **Quality System** including a written control and procedures manual implementing EUREPGAP *Fruit and Vegetables* must be in place that guarantees all internal inspections are undertaken in a competent way, and that there is a traceability system which enables the EUREPGAP certified product to be segregated from non-certified product, and enables it to be traced back to the farm or group of farms where it originated. (Annexes 2 and 3).
- (ii) **Central Administration and Management:** All registered members and farms/sites must be operating under the same management and control and sanctions system, which is centrally administered, audited and subject to central management review.
- (iii) **Contract Duration:** The Farmer Group must contract the Farmers it registers for EUREPGAP certification for the period of at least one whole year.
- (iv) **Internal Audit procedures:** All Farmer Group farms registered under EUREPGAP must have internal audit procedure(s) that establish an annual inspection of each registered farmer as a minimum.

8.2.2 Farmer Internal self-inspection:

- (i) A completed internal self-inspection based on the EUREPGAP Checklist must be available on each Registered Farm *and declared produce handling sites* for review by either the internal or the external inspector during the inspection process.
- (ii) The internal self-inspection must be carried out at least once a year. This internal self-inspection will be carried out by each registered member of the Farmer Group.

8.2.3 Farmer Group internal inspection:

- (i) A minimum of one internal inspection per annum of each registered farm *and all declared produce handling sites* within the Farmer Group must be carried out by qualified staff within the Farmer Group or subcontracted to an external verification body different from the verification body responsible for the external verification on which certification decisions are taken.
- (ii) This annual internal inspection must be based on the EUREPGAP Checklist.

8.2.4 External verification by EUREPGAP approved CB:

- (i) Audit of the Internal Quality Management and Control System occurs once before certification, subsequent Audits will be repeated annually. This "System Check" will demonstrate whether the Quality System in place is operating correctly, according to the criteria set out in Annex 2.

- (ii) External Inspection is annual and selection is made by taking a random sample that as a minimum is the square root of the total number of EUREPGAP registered farmers within the Farmer Group.
- (iii) The external inspection reports will be prepared in accordance with the requirements of EN 45011/ ISO Guide 65.
- (iv) Additional Guidelines on verification of Option 2 certification which must be followed are specified in Annex 3.

8.3 OPTIONS 3 and 4 (Benchmarking):

Option 3: Individual Farmer applies for EUREPGAP benchmarked scheme Certificate

Option 4: Farmer Group applies for EUREPGAP benchmarked scheme Certificate

8.3.1 Requirements of Applicant Scheme to achieve Benchmarking:

- (i) **Benchmarking:** The Scheme applying for Benchmarking (Applicant Scheme) is assessed for equivalence by comparing content and performance criteria against EUREPGAP. Refer to the EUREPGAP Benchmarking Procedure in its latest version.
- (ii) **Scheme Rules:** All registered Farmers/sites/farms licenced/certified are operating under the Applicant Scheme rules.
- (iii) **EUREPGAP Approved CBs:** All certification carried out within the Applicant Scheme must be done by EUREPGAP Approved CBs that must be accredited to EN 45011 or ISO 65 to the scope of the Applicant scheme and also to the EUREPGAP General Regulations of *Fruit and Vegetables*.
- (iv) **Frequency of CB verification:** the Applicant Scheme must ensure verification of Individual Farmers according to rules for OPTION 1 and of Farmer Groups according to rules for OPTION 2.

9. RIGHTS AND OBLIGATIONS OF EUREPGAP APPLICANTS

9.1 Farmer Obligations

- (i) The **Certificate owner is responsible** for Compliance of the Certified Products to the EUREPGAP Protocol within the declared extent of the certificate scopes.
- (ii) Applicant Farmers or Farmer Group **must register with a CB** as the first step towards obtaining a EUREPGAP certificate. The registration process must be finished before the first CB inspection/audit.
- (iii) A registered Farmer or Farmer Group that changes CB must **communicate the previous Registration Number(s)** assigned to him by the CB he has left (and any previous CB he has registered with under EUREPGAP) to the CB he applies to.
- (iv) A Farmer or Farmer Group **may not register** the same Farm areas **with more than one EUREPGAP Approved CB**, or under more than one Option at a time.
- (v) If a Farmer that has registered under Option 1 should enter into a Farmer Group that is registered under Option 2, then he must **give up his Option 1 registration n°**, regardless of whether the Option 2 CB he now registers with is the same or different from the CB that he has been registered with under Option 1.
- (vi) Registered Farmers are responsible for **communicating data updates** to CBs according to the internal procedures of each CB, such as farm or crop area changes and inclusion/de-listing of members within a Farmer Group.

- (vii) Farmers must **commit themselves to following the requirements** established in this General Regulations Document, including payment of the registration fee established by EUREPGAP, and declare this in a signed document held by the CB.
- (viii) Farmers take responsibility for any **Subcontractors** employed, who must comply with the relevant EUREPGAP Control Points. Refer to Annex 4: Subcontractors
- (ix) Farmers applying for EUREPGAP **must include all the Farms and Produce Handling sites** where the *crop* which they are seeking Certification for is *grown or handled* under their ownership,
- (x) The EUREPGAP Farmer/Farmer Group must make a formal declaration to the CB during registration, that states in(to) which country(ies) the EUREPGAP registered **produce is intended to be traded**. (This information is necessary for checking compliance with *Control Point 8.7.2* in the *CPC Fruit and Vegetables*.)
- (xi) If **no produce handling** (*see definitions*) is carried out, the applicant farmer must declare this formally to the CB they are applying with.

9.2 Farmer Rights

- (i) CB and Applicant will agree on **Service of Notice terms**, which must include a commitment by the CB to confirm the receipt of formal application for Registration within 14 calendar days, and to confirm first Certification within 28 calendar days after the audit or after the closure of any outstanding non-compliances.
- (ii) Any **complaints or appeals** against CBs will follow the CB's own complaints and appeals procedure which each CB must have and communicate to all its clients. In case the CB does not respond satisfactorily, the complaint can be addressed to the EUREPGAP Secretariat using the EUREPGAP complaints form and procedure, which will be made available to the plaintiff on request.
- (iii) A farmer may **change the CB** that he is registered and certified with, either voluntarily or if a situation arises where a CB that has previously been approved by EUREPGAP should become not approved (through sanctions enforcement, bankruptcy or other reasons). Refer to ANNEX 6 for clarification.
- (iv) **Confidentiality:** EUREPGAP and EUREPGAP Approved CBs will treat any information relating to the Applicant Farmer or Farmer Group including details of products and processes, evaluation reports and associated documentation as confidential (unless otherwise required by law). No information is released to third parties without the prior written consent of the Applicant except where stated otherwise in this General Regulations document.

10. EUREPGAP CERTIFICATE GRANTING PROCESS

Please refer to the flowchart in point 10.2. The following steps must be followed before certification can be granted:

10.1 Registration

All relevant documentation concerning the Farmer/Farmer Group applying for EUREPGAP certification must be recorded. This registration process must include:

- (i) **Option** applied for (1, 2, 3 or 4)
- (ii) **Identification** (name and surname of applicant, as well as company name, where applicable)
- (iii) **Full address** of the Farmer/Farmer Group with contact person and telephone-fax number.

- (iv) **Clear location** of all the farm/farms and applicable *Produce Handling* sites being certified, including *products grown* and specifying which of these *products grown* are seeking certification. It is the responsibility of the CB to have fully identified all the land area and *produce handling* sites for which the certificate is issued.
- (v) **Trade marks** under which Farmer or Farmer Group commercialise the product to be certified.
- (vi) **Signed declaration of commitment** to follow the requirements established in this General Regulations Document, including payment of the current registration fee as established by EUREPGAP.
- (vii) A Declaration that covers each *crop* registered by the Farmer/Farmer Group of any **exclusion from the *Produce Handling Module***. This declaration allows the no N/A Control Points in Section 10 of the CPCC document to be scored as N/A.
- (viii) A **Product Custody declaration** that covers each product registered, stating whether non-EUREPGAP-certified as well as EUREPGAP certified *produce* is being sourced for the *Produce Handling* operations (unless this operation is excluded from the certification).
- (ix) **Previous Registration Number(s)** of Applicant if applicable.
- (x) A declaration that covers, for each *crop*, all **countries the Farmer is intending to trade** his *produce* in.
- (xi) Agreement by the Farmer on the **disclosure of information** relative to the certification (see 10.8).

Additional voluntary information that the Farmer / Farmer Group may provide EUREPGAP include:

- (xii) EAN Global Location Number (GLN^o);
- (xiii) Unique Area ID. as defined by EUREPGAP (e.g. based on GPS);
- (xiv) Government or other official farm registration data.
- (xv) Countries of destination legislation compliance declaration. Covers the country(ies) where the Certified *Produce* is intended to be traded in **and** where the Farmer/Farmer Group can demonstrate to the CB that the applicable MRL legislation in the country(ies) of destination is complied with. Compliance will be demonstrated through successful application of a procedure which will be set out by EUREPGAP for specific countries of destination.

As a final result of acceptance of the registration **the accepting CB will provide:**

- (xvi) **Sub-licence Agreement** between CB and Farmer/Farmer Group must be signed
- (xvii) The assignment by the CB of a permanent **Registration Number**.
- (xviii) The CB will charge the Farmer/Farmer Group the current **registration fee** as established by EUREPGAP, based on the number of farms registered.

These requirements for registration may be gathered in a single document which may be attached to the **Sub-Licence Agreement** signed between the CB and the Farmer/Farmer Group. For communication of this data to EUREPGAP by the CB, see Annex 5.

10.2 Flow Chart of Registration Process

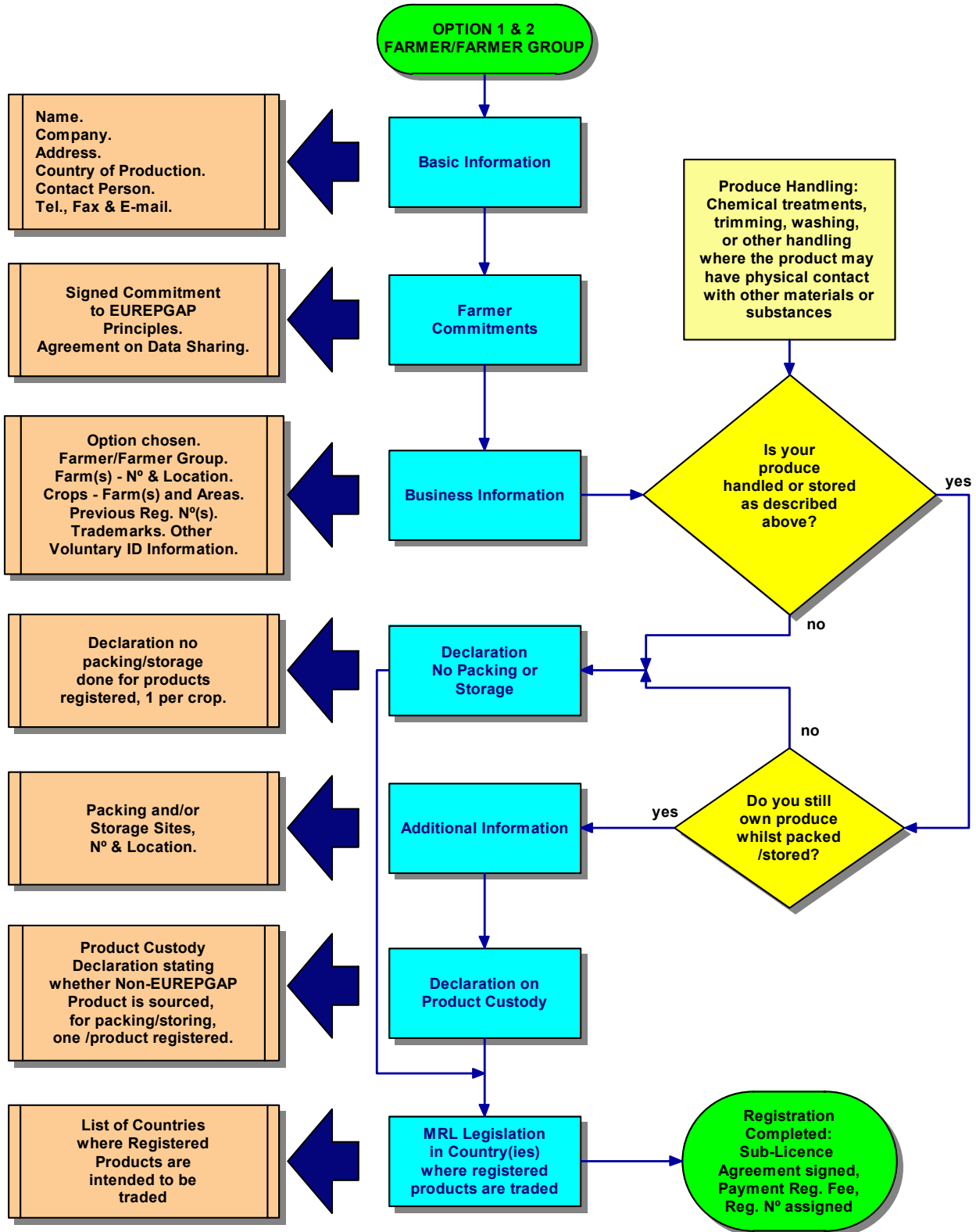

10.3 Inspection and Certification Process

- (i) As detailed in 8.1, 8.2 and 8.3 for Options 1, 2 and 3 & 4 respectively.
- (ii) Guidelines issued by the EUREPGAP TSC *Fruit and Vegetables* as mentioned in point 6.8 of this General Regulations document will be followed by CB and Farmer/Farmer Group if applicable.
- (iii) **Verification:** Inspection frequencies, reporting procedures and certification scopes are described under chapter 8 of this General Regulations Document. The registered farm and *Produce Handling* sites within that farm unit must be visited as part of the inspection activities.

10.4 Inspection Timing:

- (i) **First Inspection:** All records to be externally inspected in the first year are only valid going back up to 3 months before the date of harvest, or going back to the date of the Farmer's first Registration with EUREPGAP, whichever is longer. *Harvest* and *Produce Handling* must take place after EUREPGAP registration of the Farmer. No records that relate to harvest that has taken place before registration with EUREPGAP are valid, even if they are less than 3 months old at the time of inspection.
- (ii) **Second and subsequent Inspections:** There must be at least one *crop* of the registered scope (*Fruit and Vegetables*) that is present (present meaning in the field, in the storage, or produce that is not yet ready to *harvest* on the *plants* in the field or orchard) on the site to give the CB confidence that any other registered *crops* (if any) not present at that time are handled in compliance with EUREPGAP.
- (iii) **Granting:** The official granting of certification will include a **certificate** that will state all data as detailed in Appendix 4, and the signature by both parties of the EUREPGAP **sub-licence agreement** in the respective language, if available from EUREPGAP.

10.5 Validity of EUREPGAP certificate

- (i) Certificate granting is **conditional on compliance** by the Applicant Farmer/Farmer Group with all applicable requirements set out in this General Regulations document.
- (ii) A EUREPGAP certificate will be issued by EUREPGAP Approved CBs, with a **validity of 1 year** in accordance with the scope described.
- (iii) The **service contract** between the CB and Farmer/Farmer Group may have an initial **duration of up to 3 years**, with subsequent renewal or extension for periods of up to 3 years.
- (iv) For **guidelines** on Use of Trademark, Logo and Certificate contents, refer to Annex 1 and Appendix 4 respectively.

10.6 Granting Scopes

10.6.1 Crop scope:

- (i) Certificate and sub-licence is issued to the registered Farmer or Farmer Group, on the farms registered and products declared (according to the published EUREPGAP product *crop* list see Annex 7). "*Crop*" is not variety specific.
- (ii) In Option 2, the Registered Farmer/Farm can receive a letter of conformity from the Farmer Group, but is not allowed to refer to the EUREPGAP Certificate of the Farmer Group without the Farmer Group's consent.

10.6.2 Location scope:

- (i) All areas of production and *Produce Handling sites* of the registered *crops* on the EUREPGAP registered Farms MUST comply with EUREPGAP.

10.6.3 Crop Growing and Produce Handling scope:

- (i) The scope of the certification covers the **growing of the crop at least up to and including harvest operations**, even if ownership of the product changes before harvest, and including *Produce Handling* at least as long as each product is owned by the Farmer, Farmer Group or one of its contracted members.
- (ii) The scope of Certification can be reduced by making the *Produce Handling Section* (Section 10) Non-Applicable, only for those products where the Farmer or Farmer Group has declared that none of the following *post-harvest activities* (excluding those for processed products) are ever carried out: *storage, chemical treatments, trimming, washing, or any other handling where the product may have physical contact with other materials or substances*.

10.7 Maintaining EUREPGAP certification

- (i) The registration of the Farmer/Farm or Farmer Group and the proposed *crops* for the relevant scopes must be re-confirmed with the CB annually.
- (ii) The full audit checklist must be completed by the inspector annually for the process of certification to be carried out.

10.8 Disclosure of Information

10.8.1 Disclosure of Farmer / Farmer Group Data to the Public

The certificate owner must agree with the CB that the following information will be communicated to EUREPGAP, who will make it publicly available as long as the Certificate status remains "Certified".

- (i) Registration Number of the Certificate
- (ii) Type of organisation (Farmer or Farmer Group)
- (iii) Scheme Name and Version
- (iv) Option chosen
- (v) Country of production
- (vi) Scope of Certificate; *Crop and Produce Handling*.
- (vii) Certification Body name
- (viii) Date of latest CB inspection
- (ix) Date of Certificate Validity

10.8.2 Disclosure of Farmer / Farmer Group Data to EUREPGAP members

The certificate owner can agree in writing with the CB that the following information will be communicated to EUREPGAP, who will make it available to EUREPGAP Members on the basis of assigned access rights:

Basic information:

- (i) Name, Address and Trade name of Farmer/Farmer Group and contact e-mail
- (ii) Certification Status i.e. partially or wholly suspended, cancelled
- (iii) Where applicable Product Custody declaration, covering all registered product

Additional voluntary information:

- (iv) Status of compliance with Control Point N^os 12.6.1, 12.6.2 and 12.6.3 of the CPCC Fruit and Vegetables at the last external CB audit. Any one of the following status can be reported = No information; Compliance with Minor Musts (12.6.1 & 12.6.3); Compliance Minor Musts and Recommendeds (12.6.1, 12.6.2 & 12.6.3).
- (v) EAN UCC Global Location Number; Unique Area ID. as defined by EUREPGAP (e.g. based on GPS); Government or other official farm registration data.
- (vi) Countries of destination legislation compliance declaration. (See point 10.1 xv)

10.8.3 Disclosure of Farmer / Farmer Group Data to EUREPGAP exclusively

The certificate owner must agree with the CB that the following information will be communicated to EUREPGAP, who will not make it available and keep it confidential, for the purpose of generating overall statistics and internal EUREPGAP quality system checks:

- (i) Production Area per *crop*, on an individual farm basis (also within a Farmer Group).
- (ii) Inspector/Auditor name.

11. SANCTIONS

All Certification Bodies (for all Options) and Farmer Groups (for Options 2 and 4) must have in place a penalty procedure based on the sanctions described in this chapter.

Three types of Sanction exist within EUREPGAP: Warning, Suspension and Cancellation. They apply to non-compliances of Control Points and to Contractual issues.

11.1 Warning

11.1.1 Penalty:

A time period is given for resolving the cause of the Sanction, after which if the Warning has not yet been lifted, an Immediate Complete Suspension is imposed.

11.1.2 Duration:

The time allowed for correction will be agreed between the CB and the Farmer/Farmer Group, up to a maximum corrective action submission period of 28 calendar days from the date of the Warning.

11.2 Suspension

11.2.1 Penalty:

The Farmer/Farmer Group will be prevented from using EUREPGAP Logo/Trademark, licence/certificate or any other type of document that has any relation to EUREPGAP, for a certain period of time.

11.2.2 Duration:

The period of time will be set by the CB, and will have a maximum validity of 6 months. After this period has expired, sanctions which have not been resolved will result in Cancellation of the certificate and of the contract between the CB and the Farmer/Farmer Group.

11.2.3 Lifting of Suspension:

Suspensions will be held until there is written / visual evidence that proves that the non-compliance the suspension originated from has been resolved. The CB will decide to do an announced or unannounced audit/inspection for verification on the Farmer/Farmer Group's expenses.

11.2.4 Type:

- (i) **deferred:** Sanction procedures will not be enforced until 28 calendar days after the date that the sanction was imposed, to allow time for resolution of the non-compliance the suspension originated from. Once 28 calendar days have elapsed without resolution, the sanction imposed will be an Immediate Complete Suspension)
- (ii) **immediate** (suspension is immediate), which can be either:
 - a. **partial:** Only certain part(s) of the Certified crop(s) scope is/are Suspended.

or

- b. **complete:** The Certificate is withdrawn altogether for a period of time.

| | | |
|---|--|---|
|  | <p style="text-align: center;">GENERAL REGULATIONS FRUIT & VEGETABLES</p> <p style="text-align: center;">ENGLISH VERSION</p> | <p>Code Ref: FP 2.1 GR Version: 2.1-Jan04 Page: 21 of 31</p> |
|---|--|---|

11.3 Cancellation

11.3.1 Penalty:

Cancellation of the contract will result in the total prohibition of the use of any licence/certificate, Logo/Trademark, device or document that could relate to EUREPGAP.

11.3.2 Duration:

A Farmer/Farmer Group that has had the certificate cancelled may not re-submit for certification with EUREPGAP until 12 months after the date of cancellation.

12. NON-COMPLIANCES

All Certification Bodies (for all Options) and Farmer Groups under Option 2 and 4 must have in place a system for identifying the non-compliances described below.

Three types of non-compliances exist within EUREPGAP, Major, Minor or Contractual. They cover Control Points compliance and Contractual issues, as detailed below:

12.1 Major Must

12.1.1 Immediate Complete Suspension:

If a *Major Must* is detected and verified by the CB as not having been complied with by the Farmer / Farmer Group, who has not put in place suitable corrective actions, **nor declared it to customer(s) and CB**, Immediate Complete Suspension of the certificate for a period of 3 months is imposed. If the non-compliance of the same *Major Must* Control Point is repeated, Cancellation of the certificate is imposed.

12.1.2 Immediate Partial Suspension (following advance notification):

If the certified Farmer / Farmer Group declares a non compliance with a *Major Must* by communicating it to direct customer(s) and to the CB, **before it is detected externally by the CB**, and puts in place suitable corrective actions to avoid the re-occurrence of this Non-compliance, then an Immediate Partial Suspension of the certificate is imposed, whose extent is agreed with the CB. The extent of this immediate partial suspension can be limited to a clearly identified, traceable part of a crop or produce (field or batch) where there is a clear and identifiable traceability system on farm that permits identification of that extent.

12.2 Minor Must

12.2.1 Deferred Suspension

If more **than 5% of applicable *Minor Musts* are not complied with**, a Deferred Suspension of certificate is imposed. Where required, corrective action must be verified by the CB (by site visit or by other form of documented verification) within a maximum period of 28 calendar days.

12.3 Contractual

12.3.1 Warning

Non-compliances of minor issues agreed in the contract between the CB and the Farmer/Farmer Group will lead to a Warning. The time allowed for correction will be agreed by the CB and the Farmer/Farmer Group. The CB will request written evidence of compliance. The maximum Corrective Action submission period that a CB may itself agree will be 28 calendar days.

12.3.2 Immediate Suspension

Non-compliance of any of the agreements signed in the contract between the CB and the Farmer/Farmer Group or any issue found during the inspection that leads to technical doubts about the Farmer/Farmer Group's **way of proceeding** will lead to an Immediate Complete Suspension.

Immediate Complete Suspension will be imposed when the Farmer/Farmer Group has not fulfilled the requests of a previous Warning within the date agreed, payment has not been made of the contracted agreements, or when any modifications, changes or adjustments officially announced by EUREPGAP and communicated by the CB to the Farmer/Farmer Group have not been followed.

12.3.3 Cancellation

Non-compliance of any of the agreements signed in the contract between the CB and the Farmer/Farmer Group that **objectively shows mismanagement** on EUREPGAP related procedures at Farmer/Farmer Group level will lead to Cancellation of the Contract

12.3.4 Bankruptcy of the Farmer/Farmer Group will lead to a cancellation of the Contract.

13. SANCTIONS AND NON-COMPLIANCES APPLICATION

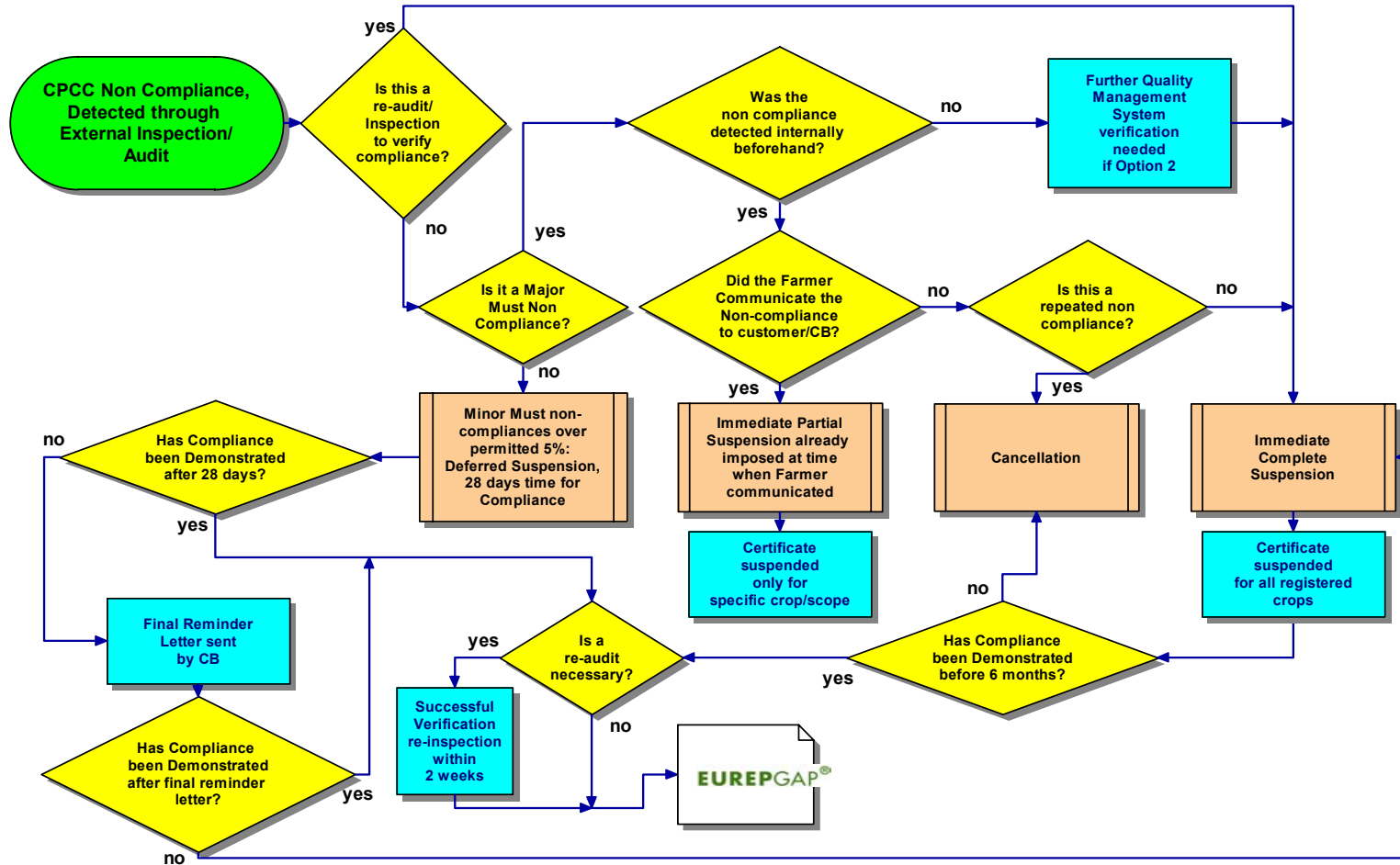

14. NOTIFICATION OF SANCTIONS, NON-COMPLIANCES AND APPEALS

14.1 Immediate communication to EUREPGAP

- 14.1.1 All Immediate Suspensions must be immediately communicated to the EUREPGAP Secretariat, forwarding the Registration Number and trademark as well as products sanctioned, by the CB or by the Farmer/Farmer Group.
- 14.1.2 See Annex 9 which sets out the details required for notification of an immediate Suspension.

14.2 Decisions on Warnings and Suspensions

- 14.2.1 Both Warnings and Suspensions will be decided by the CB Certification Committee (or equivalent decision making department).
- 14.2.2 Upon finding that a Farmer or Farmer Group no longer conforms to the EUREPGAP Standard, the Inspector will report this to his CB and to the Certified Farmer or Farmer Group, detailing the non-compliances identified during the inspection. This will lead to immediate or deferred suspension.

14.3 Farmer Resolution of Non-compliances

- 14.3.1 The Certified Farmer or Farmer Group must either resolve the non-compliances communicated or appeal to the CB in writing against the non-compliances, explaining the reasons for the Appeal.
- 14.3.2 Where a deferred suspension has been imposed, if the non-compliances are not resolved within the permitted time scale, the Certified Farmer or Farmer Group will be sent a final reminder by the CB. The final reminder must be answered by the farmer within 7 calendar days, and the CB may give the Farmer a grace period of up to 14 calendar days to satisfactorily demonstrate compliance of the outstanding non-compliance.
- 14.3.3 If the non-compliances are still not resolved after this final reminder, answering time and grace period, which must never exceed 28 days in total, the Certified Farmer or Farmer Group will be immediately suspended.

14.4 Lifting of Immediate Suspension

- 14.4.1 If the Farmer or Farmer Group that has been immediately suspended (either partial or completely) notifies the CB that the non-compliances are resolved before 6 months have elapsed, the respective suspension will be lifted, subject to satisfactory documentary evidence being provided, or for certain non-compliances subject to a satisfactory re-inspection, to verify compliance.

14.5 Non Compliances still Outstanding after 6 months

- 14.5.1 If after 6 months have passed since the Farmer or Farmer Group was suspended and the suspension has not been lifted, his/her registration and certification will be Cancelled. A fresh application will then be needed if the producer wishes to re-join the scheme, after 12 months have elapsed since the date of cancellation.
- 14.5.2 Suspension /Cancellation of the Farmer/Farmer Group and registration number does not necessarily mean the suspension of the trademark under which the Farmer or Farmer Group has been hitherto selling his products.

14.6 Sanctioning of CBs

- 14.6.1 The EUREPGAP Technical and Standards Committee for *Fruit and Vegetables* reserves the right to sanction CBs based on evidence of an improper procedure, following the Certification and Licence Agreement signed between the EUREPGAP Approved CB and EUREPGAP. This may include the immediate notification to the responsible Accreditation Body and withdrawal of EUREPGAP approval.

15. HARMONISATION PROCEDURE

- 15.1 EUREPGAP Compliance Criteria interpretation is solely set and decided by the EUREPGAP Technical and Standards Committee for *Fruit and Vegetables* and made public only through EUREPGAP official communications (See Appendix 4).
- 15.2 EUREPGAP approved CBs may propose recommendations for consideration by EUREPGAP, by sending it through the CB EUREPGAP Scheme Manager to the EUREPGAP Secretariat, who will in turn address it to the EUREPGAP Technical and Standards Committee for *Fruit and Vegetables*. This can be done at any time or at the EUREPGAP CB Workshops held for the purpose of maintaining compliance criteria harmonised, and to which the EUREPGAP approved CB is committed to sending a qualified member of staff at least annually.
- 15.3 The EUREPGAP Technical and Standards Committee for Fruit and Vegetables will consider the recommendations proposed and decide whether to incorporate them into the EUREPGAP Control Points and Compliance Criteria or other Normative Document. Only when the recommended criteria has been approved, this information will be made public incorporating it into a new edition of EUREPGAP Control Points and Compliance Criteria or as Technical Guidelines (as set out in 10.3 ii) to the latest approved version, for notification of updates see Annex 11.

| | | |
|---|---|--|
|  | GENERAL REGULATIONS FRUIT & VEGETABLES ENGLISH VERSION | Code Ref: FP 2.1 GR Version: 2.1-Jan04 Appendix: 1 Page: 26 of 31 |
|---|---|--|

16. APPENDIX 1: REQUIREMENTS FOR EUREPGAP FRUIT AND VEGETABLES AUDITOR

16.1 Formal Qualifications:

16.1.1 Post-high school diploma

- (i) A least a post high school diploma or equivalent (minimum course duration of 2 years) must have been obtained in a discipline related to the scope of the certification (*Fruit and Vegetables*).

16.2 Technical Skills and Qualifications:

16.2.1 Lead Assessor training:

- (i) Practical auditing experience (minimum 15 days).
- (ii) Lead Assessor training course must have a minimum duration of 37 hours, which must be recognised by one of the Accreditation Bodies defined in Annex 5, point 5.1.3.
- (iii) Lead Assessor training course must cover: applicable standards on Quality Auditing, Auditing Techniques, focus of the audits (Psychological aspects and communication) and reporting, it must also include a practical case study.

16.2.2 Food Safety and GAP training:

- (i) Training in HACCP principles either as part of formal qualifications or by the successful completion of a formal course based on the principles of Codex Alimentarius.
- (ii) Food hygiene training either as part of formal qualifications or by the successful completion of a formal course.
- (iii) Pesticide and fertiliser training either as part of formal qualifications, or by the successful completion of a formal course.
- (iv) A minimum of 2 years post-graduate and 3 years overall experience in the horticulture industry. This shall involve work in the production of horticultural products, or a quality assurance or food safety function within the fruit and vegetable industry.

16.2.3 Communication Skills

- (i) English language skills suitable for negotiations and communication with EUREPGAP bodies.
- (ii) "Working language" skills in the corresponding native/working language. This must include the locally used specialist terminology in this working language.
- (iii) Exceptions to this rule must be consulted beforehand with the EUREPGAP Secretariat.

| | | |
|---|--|--|
|  | <p style="text-align: center;">GENERAL REGULATIONS FRUIT & VEGETABLES</p> <p style="text-align: center;">ENGLISH VERSION</p> | <p>Code Ref: FP 2.1 GR Version: 2.1-Jan04 Appendix: 1 Page: 27 of 31</p> |
|---|--|--|

16.3 Key Tasks

16.3.1 EUREPGAP Farmer Group Audits

- (i) Auditing and assessment of the Quality Management System of Farmer Groups for compliance with the EUREPGAP Standard.
- (ii) To produce timely and accurate reports on such audits in accordance with the report format agreed with EUREPGAP.

16.3.2 EUREPGAP Farm Inspections

- (i) Inspection of farms (of either Farmers or Farmer Groups) to assess compliance with the EUREPGAP Standard.
- (ii) To produce timely and accurate reports on such inspections in accordance with the report format agreed with EUREPGAP.

16.3.3 General

- (i) To maintain up to date files of all quality policies, procedures, work instructions and documentation issued by the CB.
- (ii) To keep abreast of developments, issues and legislative changes pertaining to the sectors in which audits are carried out.
- (iii) To carry out any other tasks the CB may assign, outside the scope of EUREPGAP, so long as these activities do not contradict EN45011 / ISO 65 principles or any stipulation set down by EUREPGAP in this General Regulations document.

16.3.4 Independence and Confidentiality

- (i) Auditors are not permitted to carry out any activities which may affect their independence or impartiality, and specifically shall not carry out consultancy or training activities for the Farmer or Farmer Groups on whom they perform audits.
- (ii) Auditors must strictly observe the Company's procedures to maintain the confidentiality of information and records.

| | | |
|---|--|--|
|  | <p style="text-align: center;">GENERAL REGULATIONS FRUIT & VEGETABLES</p> <p style="text-align: center;">ENGLISH VERSION</p> | <p>Code Ref: FP 2.1 GR Version: 2.1-Jan04 Appendix: 2 Page: 28 of 31</p> |
|---|--|--|

17. APPENDIX 2: REQUIREMENTS FOR EUREPGAP FRUIT AND VEGETABLES INSPECTOR

17.1 Formal Qualifications

17.1.1 Post-high school diploma

- (i) A least a post high school diploma or equivalent (minimum course duration of 2 years) must have been obtained in a discipline related to the scope of the certification.

17.2 Technical Skills and Qualifications:

17.2.1 Food Safety and GAP training:

- (i) Training in HACCP principles either as part of formal qualifications or by the successful completion of a formal course based on the principles of Codex Alimentarius.
- (ii) Food hygiene training either as part of formal qualifications or by the successful completion of a formal course.
- (iii) Pesticide and fertiliser training either as part of formal qualifications, or by the successful completion of a formal course.
- (iv) A minimum of 2 years post-graduate and 3 years overall experience in the horticulture industry. This shall involve work in the production of horticultural products, or a quality assurance or food safety function within the fruit and vegetable industry.

17.2.2 Communication Skills

- (i) Working language skills in the corresponding native/working language. This must include the locally-used specialist terminology in this working language.
- (ii) Exceptions to this rule must be consulted beforehand with the EUREPGAP Secretariat.

17.3 Key Tasks

17.3.1 EUREPGAP Farm Inspections

- (i) Inspection of farms (of either Farmers or Farmer Groups) to assess compliance with the EUREPGAP Standard.
- (ii) To produce timely and accurate reports on such inspections in accordance with the report format agreed with EUREPGAP

17.3.2 General

- (i) To maintain up to date files of all quality policies, procedures, work instructions and documentation issued by the CB.
- (ii) To keep abreast of developments, issues and legislative changes pertaining to the sectors in which audits are carried out.
- (iii) To carry out any other tasks the CB may assign, outside the scope of EUREPGAP, so long as these activities do not contradict EN45011 / ISO 65 or any stipulation set down by EUREPGAP in this General Regulations Document.

| | | |
|---|---|--|
|  | <p style="text-align: center;">GENERAL REGULATIONS FRUIT & VEGETABLES</p> <p style="text-align: center;">ENGLISH VERSION</p> | <p>Code Ref: FP 2.1 GR Version: 2.1-Jan04 Appendix: 2 Page: 29 of 31</p> |
|---|---|--|

17.3.3 Independence and Confidentiality

- (i) Auditors are not permitted to carry out any activities which may affect their independence or impartiality, and specifically shall not carry out consultancy or training activities for the Farmer or Farmer Groups on whom they perform audits.
- (ii) Auditors must strictly observe the Company's procedures to maintain the confidentiality of information and records.

| | | |
|---|--|--|
|  | <p style="text-align: center;">GENERAL REGULATIONS FRUIT & VEGETABLES</p> <p style="text-align: center;">ENGLISH VERSION</p> | <p>Code Ref: FP 2.1 GR Version: 2.1-Jan04 Appendix: 3 Page: 30 of 31</p> |
|---|--|--|

18. APPENDIX 3: REQUIREMENTS FOR INTERNAL FARMER GROUP INSPECTOR

18.1 Formal Qualifications:

18.1.1 Post-high school diploma

- (i) A least a post high school diploma or equivalent (minimum course duration of 2 years) must have been obtained in a discipline related to the scope of the certification.

18.2 Technical Skills and Qualifications:

18.2.1 Food Safety and GAP training:

- (i) Training in HACCP principles either as part of formal qualifications or by the successful completion of a formal course based on the principles of Codex Alimentarius.
- (ii) Food hygiene training either as part of formal qualifications or by the successful completion of a formal course.
- (iii) Pesticide and fertiliser training either as part of formal qualifications, or by the successful completion of a formal course.
- (iv) A minimum of 1 year post-graduate experience in the Fruit and Vegetable industry. This shall involve work in the production of horticultural products, or a quality assurance or food safety function within the fruit and vegetable industry.

18.2.2 Communication Skills

- (i) Working language skills in the corresponding native/working language. This must include the locally-used specialist terminology in this working language.
- (ii) Exceptions to this rule must be consulted beforehand with the EUREPGAP Secretariat.

| | | |
|---|--|--|
|  | <p style="text-align: center;">GENERAL REGULATIONS FRUIT & VEGETABLES</p> <p style="text-align: center;">ENGLISH VERSION</p> | <p>Code Ref: FP 2.1 GR Version: 2.1-Jan04 Appendix: 4 Page: 31 of 31</p> |
|---|--|--|

19. APPENDIX 4: CERTIFICATE CONTENTS

19.1 The EUREPGAP Certificate shall contain the following information:

19.1.1 Basic Information

- (i) EUREPGAP Logo (only once the issuing CB has been accredited)
- (ii) Issuing CB and CB Logo
- (iii) Name and/or logo of Accreditation Body of issuing CB
- (iv) Trading Name, Name and address of Certificate owner
- (v) Name and address of Farm(s) (and *Produce Handling sites*) Certified. Where the certificate is of a Farmer Group, an appendix will form part of the Certificate which will detail all the farms covered within the Farmer Group.

19.1.2 Scope of EUREPGAP Certificate

- (i) Product scope (*Fruit & Vegetables*),
- (ii) Crop scope(s) (as in EUREPGAP list, see Annex 7)
- (iii) Declaration stating that “No *Produce Handling* certified for product(s):” [followed by the respective product(s)]
- (iv) *EUREPGAP Fruit and Vegetables Version 2.0-Jan04, (or later version of the CPCC Fruit and Vegetables that compliance has been verified to).*
- (v) Date of Certificate Validity

| | | |
|---|--|--|
|  | <p style="text-align: center;">GENERAL REGULATIONS FRUIT & VEGETABLES</p> <p style="text-align: center;">ENGLISH VERSION</p> | <p>Code Ref: FP 2.1 GR Version: 2.1-Jan04; Annex: 1; A1-0 Page: 1 of 2</p> |
|---|--|--|

1. ANNEX 1: TRADEMARK, LOGO AND REGISTRATION N° USE

(This Annex forms part of the EUREPGAP General Regulations *Fruit & Vegetables* and may be referred to by other EUREPGAP documentation.)

The EUREPGAP trademark, logo and/or registration number as defined in this document may never appear on the product, consumer packaging of the product, or at the point of sale.

1.1 EUREPGAP Trademark

The EUREPGAP Trademark is the word “EUREPGAP” in capitals, black colour Arial Font with no text effects (no bold, italics or underlining) and maximum height of 10 millimetres.

1.2 EUREPGAP Logo

1.2.1 Specifications

The EUREPGAP logo must always be obtained from EUREPGAP, this will ensure that it contains the exact corporate colour and format, as below:



1.2.2 Use of EUREPGAP logo

The EUREPGAP Secretariat makes use of the EUREPGAP Logo, and licences its restricted use to the following organisations:

- (i) EUREPGAP Associate, Retailer and Supplier Members, who may use it only in relation to membership claims and only in business to business communication,
- (ii) Accredited EUREPGAP Approved Certification Bodies, for promotion of their Accredited EUREPGAP Certification activities in business to business communication and on the Accredited EUREPGAP Certificates issued by them.
- (iii) Any other organisation, based on individual agreements, such as EUREPGAP approved Trainers, publications, etc.

1.3 EUREPGAP Registration N°

1.3.1 Specifications

- (i) The EUREPGAP trademark (see point 1.1 of this Annex), followed by a space and then the designated Certification Body name (in its short form as agreed between the CB and the EUREPGAP Secretariat: “CB Short name”), followed by the Registration number of the Farmer or Farmer Group, as issued by the Certification Body.

1.3.2 Examples:

- (i) “EUREPGAP Cert12345-12”
- (ii) “EUREPGAP Cert123-FR-01”

1.3.3 Explanation:

- (i) “EUREPGAP[SPACE][CB Short name as in Agreement between EUREPGAP Secretariat and CB][Reg. N° as assigned by CB, in alphanumeric format, without any spaces]”
- (ii) Further variations of usage can be agreed upon with EUREPGAP Secretariat.

| | | |
|---|---|--|
|  | <p style="text-align: center;">GENERAL REGULATIONS FRUIT & VEGETABLES</p> <p style="text-align: center;">ENGLISH VERSION</p> | <p>Code Ref: FP 2.1 GR Version: 2.1-Jan04; Annex: 1; A1-0 Page: 2 of 2</p> |
|---|---|--|

1.3.4 Use of EUREPGAP Registration Number

The use of the full EUREPGAP Registration N° with reference to the Certified product and/or the certified organisation is restricted to owners of accredited EUREPGAP Certificates, which can only appear on the following items:

- (i) Accredited Certificates and copies.
- (ii) Business to business communication.
- (iii) Pallets that only contain accredited EUREPGAP certified products, may in addition to the full EUREPGAP reg. N°, have a separate EUREPGAP Trademark sign to a maximum height of 100 millimetres (all other trademark conditions must be as set out in point 20.1) only when by nature of the label or the material that it is fixed to there is no possibility that it will appear at the point of sale.
- (iv) Boxes or crates or other non-retail consumer packaging, only where the owner of an accredited EUREPGAP Certificate sells the product to another EUREPGAP Certificate owner.

| | | |
|---|--|--|
|  | <p style="text-align: center;">GENERAL REGULATIONS FRUIT & VEGETABLES</p> <p style="text-align: center;">ENGLISH VERSION</p> | <p>Code Ref: FP 2.1 GR Version: 2.1-Jan04 Annex: 2; A2-0 Page: 1 of 6</p> |
|---|--|--|

2. ANNEX 2: FARMER GROUP QUALITY MANAGEMENT SYSTEMS

(This Annex forms part of the EUREPGAP General Regulations *Fruit & Vegetables* and may be referred to by other EUREPGAP documentation.)

2.1 Administration and Structure

2.1.1 Legality

There shall be documentation which clearly demonstrates that the applicant Farmer Group is a legal entity.

2.1.2 Structure:

The administrative structure of the Farmer Group shall be documented and clearly identify the relationship between the Farms/Farmers and the Farmer Group

2.1.3 Contractual Documentation

There shall be written signed contracts between each Farmer/Farm and the Farmer Group. The contracts shall include the following elements:

- (i) Name or fiscal identification of the Farmer/Farm
- (ii) Contact address
- (iii) Individual farm location
- (iv) Commitment to comply with the requirements of the EUREPGAP standard
- (v) Agreement to comply with the Farmer Group documented procedures, policies and where provided, technical advice.
- (vi) Sanctions which may be applied in case of EUREPGAP requirements not being met.

2.1.4 Farmer Register

A register shall be maintained of all EUREPGAP Farmers/Farms included within the Farmer Group scheme and of all *Produce Handling* sites used for produce grown in accordance with the EUREPGAP standard.

The register shall contain the following information for each Farmer/Farm (and *Produce Handling* site where applicable):

- (i) Name or fiscal identification of the Farmer/Farm and *Produce Handling* Site
- (ii) Contact address
- (iii) Individual farm and *Produce Handling* site location
- (iv) Registered product (species/subspecies) grown and handled at the *Produce Handling* sites.
- (v) Growing area for each registered product
- (vi) Internal audit date
- (vii) Current EUREPGAP status

| | | |
|---|---|---|
|  | GENERAL REGULATIONS FRUIT & VEGETABLES ENGLISH VERSION | Code Ref: FP 2.1 GR Version: 2.1-Jan04 Annex: 2; A2-0 Page: 2 of 6 |
|---|---|---|

2.2 Management and Organisation

2.2.1 Structure

The Farmer Group shall have a management structure and sufficient suitably trained resources to effectively ensure that the requirements of EUREPGAP are met by the registered farms. The organisational structure of the Farmer Group shall be documented and shall include where applicable:

- (i) EUREPGAP Management Representative
- (ii) Internal Audit Department
- (iii) Agricultural Technical Department
- (iv) Quality Systems Management
- (v) *Produce Handling* site Management (if applicable)

2.2.2 Responsibility and duties

The duties and responsibilities of all personnel involved with the EUREPGAP Quality system shall be documented, and there shall be a nominated individual with sufficient seniority and resources with overall responsibility for maintenance of the EUREPGAP system.

2.3 Competency and Training of Staff

- 2.3.1 The Farmer Group shall ensure that all personnel with responsibility for compliance with the EUREPGAP standard are adequately trained and meet defined competency requirements.
- 2.3.2 The competency requirements, training and qualifications for key staff shall be documented and shall meet any defined competency requirements laid out in the EUREPGAP standard.
- 2.3.3 Records of qualifications and training shall be maintained for all key staff to demonstrate competence.
- 2.3.4 Where more than one internal auditor is used there shall be a program of training and evaluation of the internal auditors e.g. by shadow audits to ensure consistency of standards and approach.
- 2.3.5 Systems shall be in place to demonstrate that key staff is informed and aware of developments, issues and legislative changes relevant to the operation of the EUREPGAP standard.

2.4 Quality Manual

- 2.4.1 The operating and quality management systems related to the EUREPGAP standard shall be documented and contained in a Quality Manual(s).
- 2.4.2 Policies and procedures shall be sufficiently detailed to demonstrate the Farmer Group's control of the principal requirements of the EUREPGAP standard.
- 2.4.3 Relevant procedures and policies shall be readily available to registered members and key staff.
- 2.4.4 The contents of the Quality Manual shall be reviewed periodically to ensure that this continues to meet the requirements of the EUREPGAP standard and Farmer Group.

| | | |
|---|---|---|
|  | GENERAL REGULATIONS FRUIT & VEGETABLES ENGLISH VERSION | Code Ref: FP 2.1 GR Version: 2.1-Jan04 Annex: 2; A2-0 Page: 3 of 6 |
|---|---|---|

2.5 Document Control

2.5.1 Quality Management System Documents:

All documentation relevant to the operation of the Quality Management System for EUREPGAP shall be adequately controlled. This shall include:

- (i) The Quality Manual
- (ii) EUREPGAP Operating Procedures
- (iii) Work instructions
- (iv) Recording forms
- (v) External standards e.g. the EUREPGAP Standard.

2.5.2 Quality Management System document control requirements:

- (i) There shall be a written procedure defining the control of documents.
- (ii) All documentation shall be reviewed and approved by authorised personnel before issue and distribution.
- (iii) All controlled documents shall be identified with an issue number, issue date/review date and be appropriately paged.
- (iv) Any change in these documents shall be reviewed and approved by authorised personnel prior to its distribution. Wherever possible an explanation of the reason and nature of the changes should be identified.
- (v) A copy of all relevant documentation shall be available at any place where the Quality Management System is being controlled.
- (vi) There shall be a system that ensures that documentation is reviewed and that following the issue of new documents, obsolete documents are effectively rescinded.

2.6 Records

- 2.6.1 The Farmer Group shall maintain records to demonstrate effective control of the EUREPGAP quality management system and compliance with the requirements of the EUREPGAP standard.
- 2.6.2 Records related to the EUREPGAP Quality systems shall be kept for a minimum of 2 years.
- 2.6.3 Records shall be genuine, legible, stored and maintained in suitable conditions and shall be accessible for inspection as required.

| | | |
|---|---|---|
|  | GENERAL REGULATIONS FRUIT & VEGETABLES ENGLISH VERSION | Code Ref: FP 2.1 GR Version: 2.1-Jan04 Annex: 2; A2-0 Page: 4 of 6 |
|---|---|---|

2.7 Complaint Handling

- 2.7.1 The Farmer Group shall have a system for effectively managing customer complaints.
- 2.7.2 There shall be a documented procedure which describes how complaints are received, registered, identified, investigated, followed up and reviewed.
- 2.7.3 The procedure shall be available to customers as required.
- 2.7.4 The procedure shall cover both complaints to the Farmer Group and against individual Farmers, Farms or *Produce handling* sites.

2.8 Internal Audit/Inspection

Internal audit systems shall be in place both to assess the adequacy and compliance of the documented quality system and to inspect farmers/Farms against the EUREPGAP standard.

2.8.1 Quality Systems Audit

- (i) The quality management system for the EUREPGAP scheme shall be audited at least annually.
- (ii) Internal Auditors shall be suitably trained and independent of the area being audited.
- (iii) Records of the internal audit plan, audit findings and follow up of corrective actions resulting from an audit shall be maintained and available.

2.8.2 Farmers/Farms Inspection

- (i) Inspections shall be carried out of each registered Farmer/Farm at least once per year against the EUREPGAP Control Points and Compliance Criteria, based on the EUREPGAP checklist. All Major and Minor Musts as well as Recommended Control Points must be inspected in full.
- (ii) There shall be a process for the review of the inspection reports and Farmers/Farms status.
- (iii) The original inspection reports and notes shall be maintained and be available for inspection as required.
- (iv) The inspection report shall contain the following information:
 - a. Identification of registered Farmer
 - b. Signature of auditee (registered member)
 - c. Date
 - d. Inspector
 - e. Registered products
 - f. Evaluation result against each EUREPGAP Control point
 - g. Details of any Non-compliances identified
 - h. EUREPGAP status.

2.8.3 Internal Inspector Requirements

- (i) Internal Inspectors shall meet the EUREPGAP Internal Farmer Group Inspector requirements as defined in appendix 3 of the General Regulations.

| | | |
|---|---|---|
|  | GENERAL REGULATIONS FRUIT & VEGETABLES ENGLISH VERSION | Code Ref: FP 2.1 GR Version: 2.1-Jan04 Annex: 2; A2-0 Page: 5 of 6 |
|---|---|---|

- (ii) Independence of internal inspector means that the inspector is able to take ultimate independent decisions regarding the compliance of the member farms/farmers within the Farmer Group, based on the internal inspection process and conclusions.

2.8.4 Non-Compliances and Corrective Action Systems

- (i) There shall be a procedure to handle non-compliances and corrective actions which may result from internal or external audits and/or inspections, customer complaints or failures of the Quality System.
- (ii) There shall be documented procedures for the identification and evaluation of non-compliances to the Quality System or operations.
- (iii) Corrective actions following a non-compliance shall be evaluated and a timescale defined for action.
- (iv) Responsibility for implementing and resolving corrective actions shall be defined.

2.9 Product Traceability and Segregation

- 2.9.1 Product meeting the requirements of the EUREPGAP standard and marketed as such shall be traceable and handled in a manner which prevents mixing with non-EUREPGAP approved products.
- 2.9.2 There shall be a documented procedure for the identification of registered products and to enable traceability from the *field/orchard/greenhouse* to the *Produce Handling* site.
- 2.9.3 The *Produce Handling* site shall operate procedures which enable registered product to be identifiable and traceable from receipt, through handling, storage and despatch.
- 2.9.4 Effective systems and procedures shall be in place to negate any risk of mislabelling or mixing of EUREPGAP registered and non- EUREPGAP approved products.

2.10 Sanctions

- 2.10.1 The Farmer Group shall operate a system of sanctions with their Farmers/Farms which meet the requirements defined in the EUREPGAP General Regulations.
- 2.10.2 Contracts with individual Farmers/Farms shall define the procedure for sanctions including the levels of Warning, Suspension and Cancellation.
- 2.10.3 The Farmer Group shall have mechanisms in place to notify the EUREPGAP approved Certification Body immediately of Suspensions or Cancellations of registered Farmers/Farms.
- 2.10.4 Records shall be maintained of all sanctions including evidence of subsequent corrective actions and decision making processes.

| | | |
|---|--|--|
|  | <p style="text-align: center;">GENERAL REGULATIONS FRUIT & VEGETABLES</p> <p style="text-align: center;">ENGLISH VERSION</p> | <p>Code Ref: FP 2.1 GR Version: 2.1-Jan04 Annex: 2; A2-0 Page: 6 of 6</p> |
|---|--|--|

2.11 Withdrawal of Certified Product

- 2.11.1 Documented procedures should be in place to effectively manage the withdrawal of registered products should this be required.
- 2.11.2 Procedures should identify the types of event which may result in a withdrawal, persons responsible for taking decisions on the possible withdrawal of product, the mechanism for notifying customers and the EUREPGAP approved Certification Body; methods of reconciling stock.
- 2.11.3 The procedure should be capable of being operated at any time.
- 2.11.4 The procedure should be tested in an appropriate manner at least annually to ensure that it is effective and records of the test retained.

2.12 Use of the EUREPGAP Logo

- 2.12.1 Use of the EUREPGAP logo on products shall be demonstrated to be under the controls of the Farmer Group and be in accordance with the EUREPGAP scheme requirements.
- 2.12.2 Where the EUREPGAP logo is to be used on registered products there shall be a written procedure defining the conditions of use in accordance with the EUREPGAP General Regulations and any EUREPGAP approved Certification Body regulations on certification which may apply.
- 2.12.3 The use of the logo shall be controlled and a register maintained of the certified products, Farmers/Farms and trade names using the logo.

2.13 Subcontractors

- 2.13.1 Procedures shall exist to ensure that any services subcontracted to third parties are carried out in accordance with the requirements of the EUREPGAP standard. (Refer to Annex 4).
- 2.13.2 Records shall be maintained to demonstrate that the competency of any subcontractor is assessed and meets the requirements of the standard.
- 2.13.3 Subcontractors shall work in accordance with the Farmer Group Quality System and relevant procedures and this shall be specified in service level agreements or contracts.

| | | |
|---|---|---|
|  | <p style="text-align: center;">GENERAL REGULATIONS FRUIT & VEGETABLES</p> <p style="text-align: center;">ENGLISH VERSION</p> | <p>Code Ref: FP 2.1 GR Version: 2.1-Jan04 Annex: 3; A3-0 Page: 1 of 4</p> |
|---|---|---|

3. ANNEX 3: GUIDELINE FOR EVALUATION OF QUALITY MANAGEMENT SYSTEMS

(This Annex forms part of the EUREPGAP General Regulations *Fruit & Vegetables* and may be referred to by other EUREPGAP documentation.)

3.1 Introduction

- 3.1.1 This document describes the systems and standards that shall be met by Farmer Groups in order to fulfil the requirements of Option 2 of the EUREPGAP standard for Fresh Fruit and Vegetables. This guideline must be followed by CBs performing external verification.
- 3.1.2 This document is based on the requirements for Farmer Groups seeking a certificate under Option 2 (as laid out in the EUREPGAP General Regulations and EN45011 / ISO Guide 65) which must be met by EUREPGAP approved CBs.

3.2 Scope

- 3.2.1 This Option 2 guideline document covers all documentation, sites, personnel and operations which are declared by the Farmer Group to be relevant and pertinent to the setting up and administration of the EUREPGAP Option 2 system.
- 3.2.2 The evaluation process will by necessity involve a sampling of these components to assess compliance with the standard and enable certification.

3.3 Evaluation Process

- 3.3.1 The evaluation process is designed to establish that the Farmer Group Quality systems and administrative structure meets the criteria for Option 2 and that the internal audits of Farmers/Farms meet the requirements for competency, independence and accuracy.
- 3.3.2 The evaluation process is therefore in two elements
 - (i) Audit of the Farmer Group Quality Management System.
 - (ii) Inspection of a sample of registered members.

3.4 Farmer Group Quality Management System Audit

- 3.4.1 The Quality audit or "System Check" will be undertaken at the central office of the Farmer Group or administrative centre for the Farmer Group scheme.
- 3.4.2 The audit will be undertaken using this Guideline.
- 3.4.3 The evaluation process will take one or more days and will include:
 - (i) Opening Meeting with Management
 - (ii) Review of all relevant documentation.
 - (iii) Evaluation of records.
 - (iv) Review of internal audits conducted on registered members.
 - (v) Discussions / interviews with key staff.
 - (vi) Closing Meeting including review of any non-compliances identified.

| | | |
|---|---|---|
|  | GENERAL REGULATIONS FRUIT & VEGETABLES ENGLISH VERSION | Code Ref: FP 2.1 GR Version: 2.1-Jan04 Annex: 3; A3-0 Page: 2 of 4 |
|---|---|---|

3.5 Inspection of Registered Members

- 3.5.1 A sample of approved registered members will be inspected against the Major and Minor control points in the EUREPGAP Checklist.
- 3.5.2 The sample size will be determined by the type of products registered, result of the audit of the Quality Management System and the size of the Farmers/Farms.
- 3.5.3 A minimum inspection sample size will be based on the square root of the number of registered Farmers/Farms. Farmers/Farms will be classified by type:
- (i) protected *crops*,
 - (ii) open field *crops*,
 - (iii) perennial *crops*
- 3.5.4 Sample size calculation shall be based on the numbers of registered Farmers/Farms separated into each crop type.
- 3.5.5 Certification Bodies can at their discretion and based on justifiable criteria increase the verification rate up to a maximum of 4 times the square root of total numbers of registered Farmers/Farms.
- 3.5.6 The sample size will be confirmed on completion of the Quality Management Systems audit.

3.6 Audit and Inspection Frequency

- 3.6.1 Farmer Group Quality Management System Audits and Inspection of a sample of Farmers/Farms will be carried out annually.

3.7 Non-Compliances

- 3.7.1 Any non-compliance identified during the evaluation will be discussed during the evaluation and documented at the end of the audit day.
- 3.7.2 Any non-compliances which show deliberate mismanagement of EUREPGAP related procedures will result in Immediate Complete Suspension of a certificate and notification to EUREPGAP Secretariat.
- 3.7.3 All non-compliances against the Quality Management System shall be resolved before a certificate can be issued to the Farmer Group. Satisfactory corrective actions must be completed to achieve approval level for any individual Farmers/Farms before the Farmers/Farms can be included on an approved list.

| | | |
|---|---|---|
|  | GENERAL REGULATIONS FRUIT & VEGETABLES ENGLISH VERSION | Code Ref: FP 2.1 GR Version: 2.1-Jan04 Annex: 3; A3-0 Page: 3 of 4 |
|---|---|---|

3.8 Corrective Actions

- 3.8.1 Evidence of the resolution of non-compliances can be provided in the form of documentary evidence or photographic evidence as appropriate.
- 3.8.2 There may be occasions where demonstration of the resolution of a non-compliance can only be confirmed by a further site visit and where this is required a charge may result.
- 3.8.3 All corrective actions will be assessed, with clarification provided to show whether the action taken and evidence provided is sufficient to close the non-compliance.

3.9 Reports

- 3.9.1 At the end of each evaluation day any non-compliances identified will be summarised and confirmed in writing to allow corrective action to be implemented.
- 3.9.2 On completion of the full evaluation process a full written report will be produced which summarises the evaluation activity undertaken, provides information on how the Farmer Group complies with the requirements of the standard, and where applicable, lists any non-compliances identified.
- 3.9.3 The evaluation report format will be according to EN45011 and in a style which meets any particular customer's requirements. The evaluation report will form the basis by which a decision can be made on the award of a certificate to the Farmer Group.
- 3.9.4 A copy of the evaluation report will be provided to the Farmer Group (within 28 calendar days of completion of the evaluation process, which ends once all corrective actions have been received). Copies will only be provided to other parties if express written authorisation is provided by the Farmer Group.

3.10 Certification

- 3.10.1 Certificates of compliance to the EUREPGAP Option 2 standards are issued under the authority of the Certification Committee of the EUREPGAP approved Certification Body. A list of all sites to which the certificate relates shall be issued in an appendix referred to in the certificate, and this list of sites shall be kept up to date by the CB.
- 3.10.2 The decision to award a certificate is taken following a review of the evaluation report, any documentary corrective actions or follow up evaluation results undertaken to sign out deficiencies. The decision to award a certificate will be taken within 28 calendar days of completion of the evaluation process, (which ends once all corrective actions have been received), and will be notified in writing to the Farmer Group.

| | | |
|---|---|---|
|  | <p style="text-align: center;">GENERAL REGULATIONS FRUIT & VEGETABLES</p> <p style="text-align: center;">ENGLISH VERSION</p> | <p>Code Ref: FP 2.1 GR Version: 2.1-Jan04 Annex: 3; A3-0 Page: 4 of 4</p> |
|---|---|---|

3.11 Registration of Additional Farmers/Farms within the Farmer Group

- 3.11.1 New Farmers/Farms may be added to the list of registered Farmers/Farms during the period of validity of the Certificate. It is the responsibility of the Farmer Group to immediately update the CB on any addition or withdrawal of sites to/from the list of registered Farmers/Farms.
- 3.11.2 Up to 10% of new Farmers/Farms in one year may be added to the approved list by registering the Farmers/Farms with the EUREPGAP approved Certification Body without necessarily resorting to further verification by the EUREPGAP approved Certification Body.
- 3.11.3 Should the number of approved registered Farmers/Farms be increased by more than 10% in one year, further sample Farmers/Farms inspections and/or a review of the Quality Management Systems may be required during that year before additional Farmers/Farms can be added to the approved list.
- 3.11.4 Regardless of the percentage by which the number of approved registered Farmers/Farms increases in one year, should the newly registered Farmers/Farms approved increase the area of previously approved registered *Crops* by more than 10% in one year, further sample Farmers/Farms inspections and/or a review of the Quality Management Systems may be required during that year before additional farms can be added to the approved list.

| | | |
|---|---|---|
|  | <p style="text-align: center;">GENERAL REGULATIONS FRUIT & VEGETABLES</p> <p style="text-align: center;">ENGLISH VERSION</p> | <p>Code Ref: : FP 2.1 GR Version: 2.1-Jan04 Annex: 4; A4-0 Page: 1 of 1</p> |
|---|---|---|

4. ANNEX 4: SUBCONTRACTORS

(This Annex forms part of the EUREPGAP General Regulations *Fruit & Vegetables* and may be referred to by other EUREPGAP documentation.)

- 4.1 Within the EUREPGAP context, subcontractors are those organisations/individuals contracted by the Farmer/Farmer Group to carry out specific tasks that are covered in the EUREPGAP Control Points and Compliance Criteria.
- 4.2 Subcontractors must be submitted to the same internal and external inspections that the Farmer/Farmer Group is, for those Control Points which apply to the tasks performed by them.
- 4.3 The subcontractor should be made aware by the Farmer/Farmer Group of the need for Compliance with EUREPGAP Control Points and Compliance Criteria.
- 4.4 The Farmer/Farmer Group is responsible for observance of the EUREPGAP Control Points applicable to the tasks performed by the Subcontractor.

| | | |
|---|---|---|
|  | GENERAL REGULATIONS FRUIT & VEGETABLES ENGLISH VERSION | Code Ref: FP 2.1 GR Version: 2.1-Jan04 Annex: 5; A5-0 Page: 1 of 3 |
|---|---|---|

5. ANNEX 5: APPROVED EUREPGAP CB REQUIREMENTS

(This Annex forms part of the EUREPGAP General Regulations *Fruit & Vegetables* and may be referred to by other EUREPGAP documentation.)

5.1 CB Approval by EUREPGAP:

- 5.1.1 CBs must have sent an Application Form and had it approved by EUREPGAP.
- 5.1.2 The EUREPGAP Certification and Licence Agreement must have been signed.
- 5.1.3 CBs must have applied to an Accreditation Body for EN 45011 or ISO 65 with EUREPGAP Scope within 28 calendar days of signing the EUREPGAP Certification and Licence Agreement, if they are not already accredited to the scope of EUREPGAP.
- 5.1.4 The Accreditation Body to which the CB applies must be part of either the European Accreditation (EA) multilateral agreement (MLA) on Product Certification, or members of International Accreditation Forum (IAF) which have been subject to a peer evaluation in the product certification field and have a positive recommendation in its report.
- 5.1.5 CBs must have obtained Accreditation within the set timeframe, which is set currently at 6 months after the date of application. This period can be extended for an additional time span if justified reasons that are acceptable to EUREPGAP are given by the CB explaining the delay.
- 5.1.6 Once Accreditation has been obtained, the CB must send a copy of the Accreditation certificate to EUREPGAP, stating clearly the extent of the accreditation scope(s).
- 5.1.7 CB must have sent a qualified inspector or auditor of the EUREPGAP scheme evaluation team to the annual compulsory EUREPGAP CB Workshop.
- 5.1.8 Registration fee must have been paid. There is a period of 60 days grace to pay the CB registration fee to EUREPGAP.
- 5.1.9 In order to grant a certificate with EUREPGAP Logo, the CB must be accredited to EN 45011 or ISO 65 with EUREPGAP Scope.

| | | |
|---|---|---|
|  | GENERAL REGULATIONS FRUIT & VEGETABLES ENGLISH VERSION | Code Ref: FP 2.1 GR Version: 2.1-Jan04 Annex: 5; A5-0 Page: 2 of 3 |
|---|---|---|

5.2 CB Operational Requirements:

- 5.2.1 All the points described in the General Regulations document MUST be accepted and included in the relevant operational document of the CB for EN 45011 (ISO 65) EUREPGAP Certification, and be available for Accreditation Body evaluation (EN 45010 / ISO 61). Any Certification Body wishing to start granting EUREPGAP licences/certificates must comply with the requirements according to point 1 of this Annex.
- 5.2.2 The CB must include the requirement for following General or Specific Guidelines issued by EUREPGAP Technical Standards Committee for *Fruit and Vegetables* into its Certification System procedures pertaining to EUREPGAP Certification. (see point 6.8 of this EUREPGAP General Regulations *Fruit and Vegetables* Document).
- 5.2.3 EUREPGAP certification granting procedure must be clearly identified in the CB operational documentation, and must follow the EUREPGAP General Regulations, starting in the first place with Registration of the Applicant.
- 5.2.4 Each CB will be responsible for the information filed; documentation must be made available to EUREPGAP on request.
- 5.2.5 Every Certification Body approved by EUREPGAP Secretariat will nominate a contact person, called “EUREPGAP Scheme Manager”, who will be the representative of the CB before EUREPGAP Secretariat. This person must be committed to assist to the harmonisation activities performed by EUREPGAP Secretariat. This person will be responsible for returning to EUREPGAP Secretariat the requested signed reception of the latest approved copy of any communication requiring written receipt. The Scheme Manager is not necessarily auditor qualified, but must at least qualify as a EUREPGAP Inspector.
- 5.2.6 The person who makes the Certification decision or at least one member of the Certification Committee shall comply with the Auditor qualifications as set out in Appendix 1.
- 5.2.7 When a Farmer / Farmer Group that has previously had a EUREPGAP Registration N° applies for registration the CB must act according to the EUREPGAP procedure for Transfer between CBs, annex 6.
- 5.2.8 The CB is responsible for communicating updates, date of first application and grace period of any new EUREPGAP Versions of Normative Documents and any Edition Updates issued by EUREPGAP to their EUREPGAP registered Farmers/Farms.
- 5.2.9 There is a provision by EUREPGAP Secretariat to allow CBs that are not yet accredited to issue a limited number of non-accredited certificates during the application phase for accreditation. The maximum number of non-accredited certificates that the applicant CB may issue for Option 1 and Option 2 is 20, unless an increase is approved on an individual basis by the EUREPGAP TSC *Fruit and Vegetables*.

| | | |
|---|---|---|
|  | GENERAL REGULATIONS FRUIT & VEGETABLES ENGLISH VERSION | Code Ref: FP 2.1 GR Version: 2.1-Jan04 Annex: 5; A5-0 Page: 3 of 3 |
|---|---|---|

5.3 CB Data Communication Requirements

CB must comply with requirements of data communication to EUREPGAP including the following:

- 5.3.1 The CB shall, on a monthly basis, update EUREPGAP on changes in Registration data, using the latest Master data format supplied by EUREPGAP.
- 5.3.2 Immediate communication by the CB (within 48 hours) of suspensions and cancellations as detailed in the sanctions procedure (using the format set out in Annex 9 of this document) and immediate (within 48 hours) electronic update (online) by the CB.
- 5.3.3 Annual statistics data covering aggregate information on non-compliances (Major, Minor and *Recommendeds*). This information will be set out in a table stating compliance per control point, country and registered product(s).
- 5.3.4 CBs assume responsibility and liability on accuracy of registration data submitted by them.

5.4 CB Communication with EUREPGAP Certification Clients

- 5.4.1 CB must comply with communication requirements to clients seeking EUREPGAP certification within the following notice times:
 - (i) Registration receipt within 14 calendar days
 - (ii) First certification confirmation within 28 calendar days of completion of evaluation process
- 5.4.2 Farm inspections can only be subcontracted to an inspection body that must be EN 45004 / ISO Guide 17020 accredited.
- 5.4.3 External auditor and inspector qualification: See Appendices 1 & 2 respectively.

5.5 Independence, Impartiality, Confidentiality and Integrity of CB:

- 5.5.1 In accordance with EN 45011, the EUREPGAP approved Certification Body must be structured to ensure **separation of activities** which could cause a conflict of interest. All Certification Body personnel must operate to high levels of professional integrity, be free from commercial, financial or other pressures, which might affect their judgment and are expressly forbidden from promoting any goods or services during evaluation activities.
- 5.5.2 **Confidentiality:** Information relating to the Applicant Farmer or Farmer Group including details of products and processes, evaluation reports and associated documentation will be treated as confidential (unless otherwise required by law). No information is released to third parties without the prior written consent of the Applicant unless stated otherwise in this document.

| | | |
|---|---|---|
|  | GENERAL REGULATIONS FRUIT AND VEGETABLES ENGLISH VERSION | Code Ref: FP 2.1 GR Version: 2.1-Jan04 Annex: 6; A6-0 Page: 1 of 2 |
|---|---|---|

6. ANNEX 6: TRANSFER BETWEEN CBs

(This Annex forms part of the EUREPGAP General Regulations *Fruit & Vegetables* and may be referred to by other EUREPGAP documentation.)

6.1 Introduction

- 6.1.1 This annex provides guidance on the transfer of EUREPGAP certificates between CBs working with EUREPGAP.
- 6.1.2 The objective of this guidance is to assure the maintenance of the integrity of EUREPGAP certificates issued by one CB if subsequently transferred to another CB.
- 6.1.3 The guidance states minimum requirements for the transfer of certificates. CBs may implement procedures or actions which are more stringent than those contained herein, provided that an organisations freedom to choose a CB is not unduly or unfairly constrained.

6.2 Transfer of Certification.

The transfer of CB is defined as the recognition of an existing and valid EUREPGAP certificate, granted by one EUREPGAP Approved CB [hereinafter referred to as the “issuing CB”] by another EUREPGAP Approved CB [hereinafter referred to as the “accepting CB”] for the purpose of issuing its own Certification.

6.3 Minimum requirements

Accepting CBs must be accredited to the EUREPGAP *Fruit and Vegetables* scope .

6.4 Pre- Transfer Review

A competent person from the accepting CB shall carry out a review of the certification of the prospective client. This review should be conducted by means of both a paper enquiry and, normally a visit to the prospective client. The review should cover the following aspects:

- (i) Confirmation that the client’s certified activities fall within the accredited scope of the accepting CB.
- (ii) The reason for seeking a transfer.
- (iii) That a valid EUREPGAP certificate, in terms of authenticity, duration, and scope of activities covered by EUREPGAP, is held in respect of the site or sites wishing to transfer. If practical, the validity of and the status of outstanding nonconformities should be verified with the issuing CB unless it has ceased trading.
- (iv) A consideration of the last evaluation/re-evaluation reports, subsequent surveillance reports and any outstanding nonconformities arising therefrom. This consideration should also include any other available, relevant documentation regarding the certification process i.e. handwritten notes, checklists.
- (v) Complaints received and action taken.
- (vi) The stage in the current certification cycle. See point 6.5.4 of this annex.

| | | |
|---|--|--|
|  | <p style="text-align: center;">GENERAL REGULATIONS FRUIT AND VEGETABLES</p> <p style="text-align: center;">ENGLISH VERSION</p> | <p>Code Ref: FP 2.1 GR Version: 2.1-Jan04 Annex: 6; A6-0 Page: 2 of 2</p> |
|---|--|--|

6.5 Certification

- 6.5.1 Transfer should normally only be of a current valid certificate but, in the case of a certificate issued by a CB that has ceased trading, or that has had its EUREPGAP Approval withdrawn, the accepting CB may, at its discretion, consider such a certificate for transfer on the basis described in this guidance.
- 6.5.2 Certificates which are known to have been suspended or to be under threat of suspension should not be accepted for transfer.
- 6.5.3 Outstanding non-compliances should be closed out, if practical, with the issuing CB, before transfer. Otherwise they should be closed out by the accepting CB.
- 6.5.4 If no further outstanding or potential problems are identified by the pre-transfer review a certificate, dated from the date of completion of the review, may be issued following the normal decision making process. The pattern of the previous certification regime should be utilised to determine the programme of on-going surveillance and re-evaluation unless, as a result of the review, the accepting CB has performed an initial or re-evaluation audit.
- 6.5.5 Where doubt continues to exist, after the pre-transfer review, as to the adequacy of a current or previously held certification, the accepting CB should, depending upon the extent of doubt, either:
 - (i) Treat the applicant as a new client, **or**
 - (ii) Conduct an evaluation concentrating on the identified problem areas
- 6.5.6 The decision as to the action required will depend upon the nature and extent of any problems found and should be explained to the organisation.

7. ANNEX 7: EUREPGAP PRODUCT CROP LIST

(This Annex forms part of the EUREPGAP General Regulations *Fruit & Vegetables* and may be referred to by other EUREPGAP documentation.)

| | | |
|-----------------|--------------|---------------------------------|
| almonds | fennel | palm trees |
| apples | figs | papayas |
| apricots | garlic | parsley |
| artichokes | gooseberries | parsnips |
| asparagus | gourds | passion fruit |
| aubergines | grapefruit | peaches |
| avocados | grapes | pears |
| baby corn | herbs | peas |
| bananas | herbs - misc | peppers |
| beans | horse radish | persimmons |
| beetroot | jack fruit | physalis |
| berries | kakis | pineapples |
| black salsify | kiwanos | plums |
| blackberries | kiwis | pomegranates |
| blueberries | kohlrabi | pomelos |
| broccoli | kumquat | potatoes |
| brussel sprouts | leeks | prickly pears |
| cabbages | lemon grass | pumpkins |
| capsicums | lemons | quinces |
| carrots | lettuce | radish |
| cauliflower | limes | raspberries |
| celeriac | litchis | rhubarb |
| celery | macadamias | satsumas |
| chard | maize | shallots |
| cherries | mandarins | soya |
| chestnuts | mangetout | spinach |
| chicory | mangoes | squashes |
| chillies | maracuyas | star fruit |
| chirimoyas | marrows | strawberries |
| chives | melons | sugar beet |
| clementines | mineolas | sultanas |
| coconuts | mulberries | swedes |
| coriander | mushrooms | sweet potatoes |
| courgettes | mustard | sweetcorn |
| cranberries | nectarines | tamarillos |
| cress | nuts | tomatoes |
| cucumbers | okras | turnips |
| currants | olives | witloof |
| custard apples | onions | yams |
| dates | oranges | |
| endives | paksoi | Updated 11 th Aug 03 |

Note: This list is indicative but not limiting, more *crops* are added as applications for certification are received. Please check in annex 11 that you have the latest valid edition of this annex.

| | | |
|---|--|--|
|  | <p style="text-align: center;">GENERAL REGULATIONS FRUIT AND VEGETABLES</p> <p style="text-align: center;">ENGLISH VERSION</p> | <p>Code Ref: FP 2.1 GR Version: 2.1-Jan04 Annex: 8; A8-1 Page: 1 of 1</p> |
|---|--|--|

8. ANNEX 8.1: CURRENT LANGUAGE EDITIONS AND STATUS

(This Annex forms part of the EUREPGAP General Regulations *Fruit & Vegetables* and may be referred to by other EUREPGAP documentation.)

| Document | Language | Version | Status | Name of Document |
|---------------------|----------|-----------|-------------------|--------------------------------|
| General Regulations | English | 2.1-Jan04 | Normative edition | EUREPGAP_GR_FP_V2-1Jan04.doc |
| CPCC | English | 2.0-Jan04 | Normative edition | EUREPGAP_CPCC_FP_V2-0Jan04.xls |
| Checklist | English | 2.0-Jan04 | Normative edition | EUREPGAP_CL_FP_V2-0Jan04.xls |

- 8.1 Editions in languages other than English that have not yet been made official through approval by the TSC will have the sentence “please refer to the English edition in case of doubt” written on each sheet in the respective language.
- 8.2 This list refers to all EUREPGAP normative documents, and is updated in conjunction with Annex 11. This list refers only to the current valid Editions.

9. ANNEX 9: EUREPGAP NON-COMPLIANCES RECORD SHEET

(This Annex forms part of the EUREPGAP General Regulations *Fruit & Vegetables* and may be referred to by other EUREPGAP documentation.)

| EUREPGAP/ Benchmarked Scheme | CB | CB Auditor Name | Date notified EUREPGAP | Date Non Conformity Identified by CB | Date Non Conformity occurred (if different) | Farmer Certificate Number | Farmer Name and Address | CPC not complied with | Date Buyer Advised |
|------------------------------------|----|-----------------------|------------------------------|---|--|---------------------------------|----------------------------|-----------------------------|-----------------------|
| | | | | | | | | | |
| | | | | | | | | | |
| | | | | | | | | | |
| | | | | | | | | | |
| | | | | | | | | | |
| | | | | | | | | | |

(The provision of this information by the CB is for immediate communication purposes only and does not substitute the regular information that should be supplied to EUREPGAP as stated in Annex 5.)

| | | |
|---|--|--|
|  | <p style="text-align: center;">GENERAL REGULATIONS FRUIT AND VEGETABLES</p> <p style="text-align: center;">ENGLISH VERSION</p> | <p>Code Ref: FP 2.1 GR Version: 2.1-Jan04 Annex: 10; A10-0 Page: 1 of 9</p> |
|---|--|--|

10. ANNEX 10: EUREPGAP DEFINITIONS

(This Annex forms part of the EUREPGAP General Regulations *Fruit & Vegetables* and may be referred to by other EUREPGAP documentation.)

- 10.1 Applicant Farmer or Farmer Group: Candidate for Certification that has applied or is in the process of applying for Certification by a EUREPGAP approved CB.
- 10.2 Approved Farmer (or Farmer Group): Applicant that has successfully applied and obtained a Certificate by a CB approved by EUREPGAP
- 10.3 Active ingredient: In any pesticide product, the component that kills, or otherwise controls, target pests. Pesticides are regulated primarily on the basis of active ingredients.
- 10.4 Annual crop: "When the time period between end of propagation stage to first harvest date is less than 12 months". For potatoes: Mother crop is seed treatment, not propagation material. Also covered are Strawberries, asparagus, cassava.
- 10.5 Arable land: Land worked regularly, generally under a system of crop rotation, which includes fallow land.
- 10.6 Audit: See ISO 9000:2000 A systematic and functionally independent examination to determine whether quality and food safety activities and results comply with planned procedures and whether these procedures are implemented effectively and are suitable to achieve objectives;
- 10.7 Benchmark: A measurable set of variables used as a baseline or reference in evaluating the performance of Quality Schemes.
- 10.8 Biennial: A plant which completes its life cycle within two years and then dies.
- 10.9 Biodiversity: Assemblage of living organisms from all sources including terrestrial, marine and other aquatic ecosystems and the ecological complexes of which they are part.
- 10.10 Body of surface water: A discrete and significant element of surface water such as a lake, reservoir, a stream, river or canal, part of a stream, river or canal, a transitional water or a stretch of coastal water.
- 10.11 Buffer zone: The region near the border of a protected area; a transition zone between areas managed for different objectives.
- 10.12 Bund: A barrier on the surface of the soil to prevent runoff, spillage and soil erosion.
- 10.13 Bunded: That is surrounded by a Bund.
- 10.14 Calibration: Measurement of the uncertainty degree of the machinery used to apply any product. Set of operations that establish, under specified conditions, the relationship between values of quantities indicated by measuring instrument and the corresponding values realised by standards.
- 10.15 Certification: All those actions leading to the issuing of a certificate in terms EN45011 /ISO Guide 65 Product Certification
- 10.16 Certification Committee: Decision making person or group of persons within a CB that has the responsibility for making the final decision on whether an Applicant Farmer or Farmer

| | | |
|---|--|--|
|  | <p style="text-align: center;">GENERAL REGULATIONS FRUIT AND VEGETABLES</p> <p style="text-align: center;">ENGLISH VERSION</p> | <p>Code Ref: FP 2.1 GR Version: 2.1-Jan04 Annex: 10; A10-0 Page: 2 of 9</p> |
|---|--|--|

Group become an Approved Farmer

- 10.17 Chain of Custody: An unbroken trail of acceptability that ensures the physical security of data, records and/or samples. Also: a process used to maintain and document the chronological history of the evidence.
- 10.18 Compost: The controlled biological decomposition of organic material in the presence of air to form a humus-like material. Controlled methods of composting include mechanical mixing and aerating, ventilating the materials by dropping them through a vertical series of aerated chambers, or placing the compost in piles out in the open air and mixing it or turning it periodically.
- 10.19 Composting: The controlled biological decomposition of organic material in the presence of air to form a humus-like material. Controlled methods of composting include mechanical mixing and aerating, ventilating the materials by dropping them through a vertical series of aerated chambers, or placing the compost in piles out in the open air and mixing it or turning it periodically.
- 10.20 Consumer: An individual who buys products or services for personal use and not for manufacture or resale.
- 10.21 Contamination in storage sites: EU 19-12-2000/365 Regulation: Contamination arising from food, storage environment, and cleaning substances and pests
- 10.22 Corridor: (1) A linear strip of land identified for present or future location of transportation or utility rights-of-way within its boundaries. (2) A thin strip of vegetation used by wildlife and potentially allowing movement of biotic factors between two areas.
- 10.23 Cover crop: A close-growing crop grown to protect and improve soils between periods of regular *crops* or between trees and vines in orchards and vineyards.
- 10.24 Critical Control Point (CCP): A point, step, or procedure at which control can be applied and a safety hazard can be prevented, eliminated, or reduced to acceptable levels
- 10.25 Critical defect: A deviation at a CCP which may result in a hazard
- 10.26 Critical limits: The maximum or minimum value to which a physical, biological, or chemical hazard must be controlled at a critical control point to prevent, eliminate, or reduce to an acceptable level the occurrence of the identified food safety hazard (adopted from Corlett, 1998 as the 1996 FSIS-USDA/1997 NACMCF definition).
- 10.27 Critical non-compliance: An incident that results in --
- 10.27.1 no confidence in the product compliance with quality and food safety requirements for export; or
 - 10.27.2 no confidence that a Quality and Food Safety Management System is in place and being operated as per the company's procedures and immediately places export certification at risk;
- 10.28 Critical load: (1) Carrying capacity is the ability of eco-systems/the earth to bear environmental load without significant damage. The threshold is the critical load. (2) The maximum load that a given system can tolerate before failing.
- 10.29 Crop: the plants which produce the Produce.

| | | |
|---|--|--|
|  | <p style="text-align: center;">GENERAL REGULATIONS FRUIT AND VEGETABLES</p> <p style="text-align: center;">ENGLISH VERSION</p> | <p>Code Ref: FP 2.1 GR Version: 2.1-Jan04 Annex: 10; A10-0 Page: 3 of 9</p> |
|---|--|--|

- 10.30 Crop Protection Product risk analysis: Covers the following risks,
- 10.30.1 Exceeding MRLs,
 - 10.30.2 legal registration issues
 - 10.30.3 Residue analysis decision taking
 - 10.30.4 Reasons behind decision taking for Residue Analysis
- 10.31 Crop rotation: A crop rotation system means that the crops on a certain plot are following other crops according to a predefined plan. Normally the crops are changed annually, but they can also be multiannual.
- 10.32 Crop rotation: The practice of growing different crops in recurring succession on the same land. Crop rotation plans are usually followed for the purpose of increasing soil fertility and maintaining good yields.
- 10.33 Crop year: Generally, the 12-month period from the beginning of harvest of a particular crop.
- 10.34 Customer: A customer is anyone who purchases products or services from a supplier.
- 10.35 Declaration: Written statement that covers the relevant subject, and which is signed by the Farmer/Farmer Group that makes the statement, and will be taken by the CB as evidence for verification of compliance to the applicable points.
- 10.36 Deviation: Failure to meet a critical limit
- 10.37 Drainage basin: The area of land that drains water, sediment and dissolved materials to a common outlet at some point along a stream channel.
- 10.38 Documentation audit: A review by an auditing panel of the company's Quality and Food Safety Management System manual;
- 10.39 Environment: water, air, land, wild species of fauna and flora, and any interrelationship between them, as well as any relationship with living organisms;
- 10.40 Farm: A farm is an agricultural production unit or group of agricultural production units, covered by the same operational procedures, farm management, and EUREPGAP decision making activities.
- 10.41 Farmer: Person or business representing the farm, (horticultural, agricultural or livestock, according to the relevant scope) who has legal responsibility for the products sold by that farming business.
- 10.42 Farmer Group: Group of farmers applying for certification with an internal procedure and internal control of 100 % of members registered to the EUREPGAP requirements. It must have legal structure, contracts with each farmer, stating entry and exit requirements, stipulated suspensions, agreement to comply with EUREPGAP requirements for registered members. List of all members of the FARMER GROUP with registration status must be available. The FARMER GROUP must have a management representative with ultimate responsibility.
- 10.43 Field, orchard or greenhouse: Separate units of land within a farm, which summed up as a whole, form a farm.

| | | |
|---|--|--|
|  | <p style="text-align: center;">GENERAL REGULATIONS FRUIT AND VEGETABLES</p> <p style="text-align: center;">ENGLISH VERSION</p> | <p>Code Ref: FP 2.1 GR Version: 2.1-Jan04 Annex: 10; A10-0 Page: 4 of 9</p> |
|---|--|--|

- 10.44 Food safety: The assurance that food will not cause harm to the consumer when it is prepared and consumed according to its intended use;
- 10.45 Groundwater: All water which is below the surface of the ground in the saturation zone and in direct contact with the ground of the soil.
- 10.46 Harvesting containers: Containers used for transporting produce during harvest.
- 10.47 Harvesting tools: gloves, scissors, knives, clippers, etc.
- 10.48 Hazard: A biological, chemical, physical or any other property that may cause a product to be unsafe for consumption.
- 10.49 Herbicide: A chemical that controls or destroys undesirable plants.
- 10.50 Individual Farmer: A Body or Person Responsible for on-farm production, who retains ownership of all the produce covered in his EUREPGAP certificate, and is a Legally acting individual or organisation that represents the farm enterprise.
- 10.51 Inspection: The examination of food or systems for control of food, raw materials, processing and distribution, including in-process and finished product testing, in order to verify compliance to requirements; See also ISO 9000: 2000
- 10.52 Integrated crop management (Croplife International): ICM is a farming system that meets the requirements of long-term sustainability. It is a whole-farm strategy which involves managing crops profitably, with respect for the environment, in ways which suit local soil, climatic and economic conditions. It safeguards the farm's natural assets in the long term. ICM is not a rigidly defined form of crop production but is a dynamic system which adapts and makes sensible use of the latest research, technology, advice and experience.
- 10.53 Integrated farm management: An approach to farming which aims to balance production with economic and environmental considerations by means of a combination of measures including crop rotation, cultivations, appropriate crop varieties and careful use of inputs.
- 10.54 Integrated pest control: The rational application of a combination of biological, biotechnical, chemical, cultural or plant-breeding measures whereby the use of chemical plant protection products is limited to the strict minimum necessary to maintain the pest population at levels below those causing economically unacceptable damage or loss.
- 10.55 Integrated Pest Management (IPM) – (Croplife International): The careful consideration of all available pest control techniques and subsequent integration of appropriate measures that discourage the development of pest populations and keep pesticides and other interventions to levels that are economically justified and reduce or minimise risks to human health and the environment. IPM emphasises the growth of a healthy crop with the least possible disruption to agro-ecosystems and encourages natural and or non-chemical pest control mechanisms.
- 10.56 Major non-compliance: Means an incident that results in --
- 10.56.1 a decrease in confidence in the product compliance with quality and food safety requirements for export; or
 - 10.56.2 a decrease in confidence in the Quality and Food Safety Management System to the extent that ongoing provision of Export Certification is in doubt and requires corrective action to be implemented immediately in order to

| | | |
|---|--|--|
|  | <p style="text-align: center;">GENERAL REGULATIONS FRUIT AND VEGETABLES</p> <p style="text-align: center;">ENGLISH VERSION</p> | <p>Code Ref: FP 2.1 GR Version: 2.1-Jan04 Annex: 10; A10-0 Page: 5 of 9</p> |
|---|--|--|

regain confidence that Export Certification meets requirements;

- 10.57 Manure organic fertilizer: non-proprietary organic fertilizer; Animal excreta collected from stables and barnyards with or without litter; used to enrich the soil.
- 10.58 Minor non-compliance: Means an incident that results in --
- 10.58.1 a decrease in confidence in the product compliance with quality and food safety requirements for export; or
 - 10.58.2 a decrease in confidence in the Quality and Food Safety Management System but not immediately placing Export Certification at risk;
- 10.59 New agricultural site: Land being cropped or planted for the first time after being used for animal production or non-food uses, excluding "soil improvement" crops.
- 10.60 Non-compliance: Means an incident where the requirements of a standard are not met
- 10.61 Non-conforming: Means the same as non-compliance
- 10.62 Inorganic fertilizer: Commercial chemical fertilizer
- 10.63 Nutrient balance: The soil surface nitrogen balance is calculated as the difference between the total quantity of nitrogen inputs entering the soil and the quantity of nitrogen outputs leaving the soil annually, based on the nitrogen cycle.
- 10.64 Organic agriculture: Refer to 2000/2092 legislation
- 10.65 Overexploitation: The use of raw materials excessively without considering the long-term ecological impacts of such use.
- 10.66 Packhouse: Any facility set up for handling harvested produce (see *Produce Handling*). Only those packhouses which do not pack the EUREPGAP registered *produce* in the final consumer package and/or do not process the produce by changing its shape or appearance are included in the EUREPGAP certificate scope for *Fruit and Vegetables*.
- 10.67 Participant: synonymous with Approved Farmer or Farmer Group
- 10.68 Pesticide: Plant Protection Product
- 10.69 Plants: live plants and live parts of plants, including fresh fruit and seeds;
- 10.70 Plant protection products: active substances and preparations containing one or more active substances, put up in the form in which they are supplied to the user, intended to:

- 10.70.1 Protect plants or plant products against all harmful organisms or prevent the action of such organisms, in so far as such substances or preparations are not otherwise defined below;
- 10.70.2 Influence the life processes of plants, other than as a nutrient, (e.g. growth regulators);
- 10.70.3 Preserve plant products, in so far as such substances or products are not subject to special Council of Commission provisions on preservatives;
- 10.70.4 Destroy undesired plants; or
- 10.70.5 Destroy parts of plants, check or prevent undesired growth of plants
- 10.71 Pollution prevention: The use of materials, processes, or practices to reduce, minimise, or eliminate the creation of pollutants or wastes. It includes practices that reduce the use of toxic or hazardous materials, energy, water, and/or other resources.
- 10.72 Post harvest chemicals: Includes post harvest crop protection products, includes wax, detergents, lubricants,
- 10.73 Potable water: water which meets the quality standards of drinking water such as those described in the WHO published Guidelines for the Safe Use of Wastewater and Excreta in Agriculture and Aquaculture
- 10.74 Preventive measure: Physical, chemical, or other factors that can be used to control an identified health hazard (adopted from Corlett, 1998).
- 10.75 Primary product: "Not processed" (See definition for processed product).
- 10.76 Processed product: When the structure of the product is altered in appearance or form
- 10.77 Produce: The harvested product of the Crop after it has been harvested, before it is sold.
- 10.78 Produce handling: Low Risk produce handling activities on-farm, i.e., packing, storage, and transport ex farm, but excluding harvesting and on-farm transport from point of harvest to first point of storage/packing. Packing carried out at point of harvest is considered Produce Handling. Also any storage, chemical treatments, trimming, washing, or any other handling where the product may have physical contact with other materials or substances.
- 10.79 Product: the Produce sold to customers.
- 10.80 Product tracking is the capability to follow the path of a specified unit of a product through the supply chain as it moves between organisations. Products are tracked routinely for obsolescence, inventory management and logistical purposes. Within the context of EUREPGAP Fresh Fruit and Vegetables this means tracking produce from the farmer to his immediate customer.
- 10.81 Product tracing is the capability to identify the origin of a particular unit and/or batch of product located within the supply chain by reference to records held upstream in the supply chain. Products are traced for purposes such as product recall and investigating complaints. Within the context of EUREPGAP Fresh Fruit and Vegetables this means tracing produce from the farmer's immediate customer back to the farmer and certified farm.
- 10.81.1 From the point of view of the user, traceability may be defined as following-up products in both a qualitative and quantitative manner within space and time.
- 10.81.2 From an information management point of view, implementing a traceability

| | | |
|---|---|---|
|  | GENERAL REGULATIONS FRUIT AND VEGETABLES ENGLISH VERSION | Code Ref: FP 2.1 GR Version: 2.1-Jan04 Annex: 10; A10-0 Page: 7 of 9 |
|---|---|---|

system within a supply chain involves systematically associating a flow of information with a physical flow. The objective is to be able to obtain pre-defined information concerning batches or groups of products (also pre-defined) at any given moment, using one or more key identifiers.

- 10.82 Record: A record is a document that contains objective evidence which shows how well activities are being performed or what kind of results are being achieved.
- 10.83 Registered Product Crop (or Crop of Registered Product): The crop that produces the product that has been registered by the Farmer with the CB under EUREPGAP.
- 10.84 Registered Product Produce: The Produce that is a result of the Registered Product Crop
- 10.85 Registration: The process by which an Individual Farmer or Farmer Group starts the application process for Certification. Once a Farmer or Farmer Group has registered he becomes an Applicant Farmer or Farmer Group.
- 10.86 Registration Number: The number given to a Farmer or Farmer Group when he has completed the Registration.
- 10.87 Resolved: Positive Closure of a non-compliance.
- 10.88 Rinsate: The mixture of the water used for rinsing together with remnants of the crop protection product and water mixture that results from the process of rinsing the Crop Protection Product application machinery/containers.
- 10.89 Risk: An estimate of the likely occurrence of a hazard
- 10.90 Risk analysis: Means an estimate of the probability of the occurrence of a hazard or other non-conformity with regard to quality and food safety;
- 10.91 Robust wall: A non-flammable physical barrier that does not allow liquid, gaseous or dust contact to occur between the two sides.
- 10.92 Sanitised: Washed with a disinfectant. (Disinfection)
- 10.93 Scope: Scope can be defined by the following three concepts:
- 10.93.1 **Product:** Horizontal Scope, EUREPGAP Protocol
 - 10.93.2 **Crop:** Refers to the official EUREPGAP crop list, within the EUREPGAP Product Scope
 - 10.93.3 **Chain integration:** Includes different parts of the chain.
- 10.94 Self-Inspection: internal inspection of the registered product crop carried out by the Farmer on his farm using a checklist based on the EUREPGAP checklist.
- 10.95 Severity: The seriousness of a hazard.
- 10.96 Sewage sludge: The accumulated settled solids separated from various types of water either moist or mixed with liquid component as a result of natural or artificial processes.
- 10.97 Signature: Must be a personal, non-transferable, visible and infallible identifier of the person, which is recorded manually, either by handwriting or « pressing a button ». Password protection alone does not guarantee individual identification.

| | | |
|---|--|--|
|  | <p style="text-align: center;">GENERAL REGULATIONS FRUIT AND VEGETABLES</p> <p style="text-align: center;">ENGLISH VERSION</p> | <p>Code Ref: FP 2.1 GR Version: 2.1-Jan04 Annex: 10; A10-0 Page: 8 of 9</p> |
|---|--|--|

- 10.98 Subcontractor: Specific farm operations performed under contract between the farmer and the contractor. The contractor furnishes labor, equipment, and materials to perform the operation. Custom harvesting of grain, spraying and picking of fruit, and sheep shearing are examples of custom work. Within the EUREPGAP context, subcontractors are those organisations/individuals contracted by the Farmer/Farmer Group to carry out specific tasks that are covered in the EUREPGAP Control Points and Compliance Criteria.
- 10.99 Substrate: Any growing medium used for holding plants in place of soil, and that has been imported to the site, and can be removed after use.
- 10.100 Suitable laboratory: Currently accredited to EN 45001 or GLP or its national equivalent or that can demonstrate via documentation that it is in the process of gaining accreditation
- 10.101 Supplier: A supplier is a person or an organization that provides products or services to customers
- 10.102 Surface water: All waters on the surface of the Earth found in rivers, streams, ponds, lakes, marshes, wetlands, as ice and snow, and transitional, coastal and marine waters.
- 10.103 Sustainable water sources: Those water sources that are under a sustainable method of management. I.e. one that “ensure[s] the health of aquatic ecosystems and balance the water needs of the environment with the water needs for economic development and agricultural purposes”
- 10.104 System Check: Audit of the Internal Quality Management and Control System
- 10.105 Technically responsible person: Person responsible for taking technical decisions regarding the certified product. This can be for a specific area of responsibility or overall, and may either be the Farmer or an Adviser..
- 10.106 Toilet: Facility where the persons may defecate and urinate in a hygienic manner (including waste disposal) and poses no food safety contamination risk to surrounding field area whilst ensuring privacy of the person.
- 10.107 Top soil: The upper part of the soil profile that is relatively rich in humus, which is technically known as the A-horizon of the soil profile.
- 10.108 Traceability: the ability to retrace the history, use or location of a product (that is the origin of materials and parts, the history of processes applied to the product, or the distribution and placement of the product after delivery) by the means of recorded identification".
- 10.109 Validation audit: Means a comprehensive evaluation of the entire Quality and Food Safety Management system to ensure that the procedures as documented in the company's Quality and Food Safety Management System manual are implemented and are effective;
- 10.110 Verification audit: routine unannounced audits of the Quality and Food Safety Management System after approval to ensure that the Quality and Food Safety Management System in place is adequately maintained.
- 10.111 Verification of calibration: Recorded verification of the correct functioning of the machinery used to apply any agrochemical.
- 10.112 Verification: Confirmation by examination and provision of evidence that specified requirements have been met, providing a means for checking that the deviation between

| | | |
|---|--|--|
|  | <p style="text-align: center;">GENERAL REGULATIONS FRUIT AND VEGETABLES</p> <p style="text-align: center;">ENGLISH VERSION</p> | <p>Code Ref: FP 2.1 GR Version: 2.1-Jan04 Annex: 10; A10-0 Page: 9 of 9</p> |
|---|--|--|

values indicated by a measured instrument and corresponding known values of a measured quantity are consistently smaller than the maximum allowable error defined in a standard or specification peculiar to the management of the measuring equipment.

- 10.113 Weed: Any plant growing where it is not wanted. In agriculture, used for a plant which has good colonising capability in a disturbed environment, and can usually compete with a cultivated species therein. Weeds are typically considered as unwanted, economically useless or pest species.
- 10.114 Worker: Any person on the farm that has been contracted to carry out a task. This includes farm owners and managers.
- 10.115 Working language: language in which an audit/inspection can be carried out independently without a translator.

Note: This list of definitions indicative but not limiting; more definitions are added by EUREPGAP as the need arises, changing the numbering – the pre-established order is Alphabetic for the first letter of the term defined. Please check in annex 11 that you have the latest valid edition of this annex.

| | | |
|---|---|---|
|  | GENERAL REGULATIONS FRUIT AND VEGETABLES | Code Ref: FP 2.1 GR Version: 2.1-Jan04 Annex: 11; A11-1 Page: 1 of 1 |
| | ENGLISH VERSION | |

11. ANNEX 11.1: FRUIT AND VEGETABLES EDITION UPDATES AND VALID VERSION REGISTER

| General Reg. Version | Replaces | Replaced doc. obsolete | Comes into force | Description of Addition/ Modification |
|----------------------------|---------------------------|-----------------------------|------------------|--|
| 2.0-Jan04 | version Sept 2001 Rev. 01 | See Point 5.8 General Regs. | Pre-release | New EUREPGAP Version edition, inclusion of annexes and detailed, structured explanation of EUREPGAP Certification Processes. |
| 2.1-Jan04 | 2.0-Jan04 | Immediately | 12 Sep. 03 | Throughout – Version name change from 2.0-Jan04 to 2.1-Jan04. Point 5.3 – Annex list now refers to most up to date version Point 5.4 – EUREPGAP official language editions the only valid docs in that language, reference to English edition made for translated documents until they become normative. “Official” and “Normative” terms used more clearly. Point 5.5 – Adapts wording to changes in Annex 11. Point 5.8 – Date of 1 st Certification brought forward to 12 th Sep. 03, date of last certification to Version Sept. 2001 Rev.01 31 st Dec 04. Point 5.9 – Detailed explanation of Version and edition handling and updates, with examples. Corrected references to “Version” and “Edition” throughout document. |
| | | | | |
| | | | | |
| | | | | |
| CPC Version | | | | |
| 2.0-Jan04 | version Sept 2001 Rev. 01 | See Point 5.8 General Regs. | 12 Sep. 2003 | New EUREPGAP Version edition, revision of every control point in the light of 2 years practical application, and current industry and consumer demands. New format and printable in Black and white. |
| Checklist Version | | | | |
| 2.0-Jan04 | version Sept 2001 Rev. 01 | See Point 5.8 General Regs. | 12 Sep. 2003 | New EUREPGAP Version edition, copies the questions in the revised CPC. |
| Gen. Reg. Annex Ed. | | | | |
| A8.1 | Annex A8.0 | Immediately | 12 Sep. 2003 | All Normative documents now covered. Documents in different languages referred |

EUREPGAP_GR_FP_V2-1Jan04.doc

| | | |
|---|---|---|
|  | GENERAL REGULATIONS FRUIT AND VEGETABLES | Code Ref: FP 2.1 GR Version: 2.1-Jan04 Annex: 11; A11-1 Page: 2 of 1 |
| | ENGLISH VERSION | |

| | | | | |
|-------|-------------|-------------|-------------|--|
| | | | | to as "Editions". Notes below table. |
| A11.1 | Annex A11.0 | Immediately | 12 Sep 2003 | Edition updates listed. Notes below table. Table format changed. |

- 11.1 Updates will be sent to the CB EUREPGAP Scheme Managers, who must sign them and distribute them internally and to all registered and applicant farmers/farms.
- 11.2 The updates registered in this table are those that cover issues of the General Regulations, its annexes (separately specified), CPCC documents and their Technical Guidelines, and EUREPGAP Checklist.
- 11.3 Annexes will only be mentioned if they have had edition updates since Edition of Version 2.0-Jan04 of the General Regulations.
- 11.4 This list is updated in conjunction with Annex 8, CURRENT LANGUAGE EDITIONS AND STATUS.